

SPECIAL SELECTION **IKO** VOL.2

See you again at
Planet IKO
<http://www.ikont.co.jp/>

*New models are introduced!
Wide range of variations!*

LW L

Linear Way L

CAT-57116 U.S. PATENTED



NIPPON THOMPSON CO., LTD.

Head office : 19-19 Takanawa 2-chome
Minato-ku, Tokyo 108-8586, Japan
Phone : Tokyo (03)3448-5850
Fax : (03)3447-7637
E-mail : ntt@ikonet.co.jp
URL : <http://www.ikont.co.jp/>
Plant : Gifu, Kamakura

IKO International, Inc.

- 91 Walsh Drive
Parsippany, NJ 07054
U.S.A.
Phone: (973)402-0254
Toll Free: 1-800-922-0337
Fax: (973)402-0441
E-mail: eco@ikonet.co.jp
- 500 East Thorndale Avenue
Wood Dale, IL 60191
U.S.A.
Phone: (630)766-6464
Toll Free: 1-800-323-6694
Fax: (630)766-6869
E-mail: mwo@ikonet.co.jp
- 20170 South Western Avenue
Torrance, CA 90501
U.S.A.
Phone: (310)609-3988
Toll Free: 1-800-252-3665
Fax: (310)609-3916
E-mail: wco@ikonet.co.jp
- 2150 Boggs Road, Suite 100
Duluth, GA 30096
U.S.A.
Phone: (770)418-1904
Toll Free: 1-800-874-6445
Fax: (770)418-9403
E-mail: seo@ikonet.co.jp
- 8105 N. Beltline Road
Suite 130, Irving, TX 75063
U.S.A.
Phone: (972)929-1515
Toll Free: 1-800-295-7886
Fax: (972)915-0060
E-mail: sw@ikonet.co.jp

Nippon Thompson Europe B.V.

- Sheffieldstraat 35-39
3047 AN Rotterdam
The Netherlands
Phone: 010-4626868
Fax: 010-4626099
E-mail: nte@ikonet.co.jp
- Mündelheimer Weg 56
40472 Düsseldorf
Germany
Phone: 0211-414061
Fax: 0211-427693
E-mail: ntd@ikonet.co.jp
Donaustauer Str. 200
93059 Regensburg
Germany
Phone: 0941-447737
Fax: 0941-447747
- 2 Vincent Avenue, Crownhill
Milton Keynes Bucks MK8 OAB
United Kingdom
Phone: 01908-566144
Fax: 01908-565458
E-mail: sales@iko.co.uk
- Autovia Madrid-Barcelona, Km. 43,700
Polig. Ind. AIDA, A-8, Ofic. 2, 1ª
19200-Azuqueca de Henares
Guadalajara, Spain
Phone: 949-263390
Fax: 949-263113
E-mail: nts@ikonet.co.jp
- Roissypole Le Dôme
2 rue de La Haye
BP 10950 Tremblay en France
95733 Roissy C. D. G. Cedex
France
Phone: 01-48165739
Fax: 01-48165746
E-mail: ntf@ikonet.co.jp

Although all data in this catalog has been carefully compiled to make the information as complete as possible, NIPPON THOMPSON CO., LTD. shall not be liable for any damages whatsoever, direct or indirect, based upon any information in this catalog. NIPPON THOMPSON CO., LTD. makes no warranty, either express or implied, including the implied warranty of merchantability or fitness for a particular purpose.

Very small size Linear Way realized by adopting a two-row simple structure

IKO Linear Way L is a miniature type linear motion rolling guide, incorporating two rows of steel balls arranged in four-point contact with the raceways. Owing to its simple design, it provides stable accuracy and rigidity even in operations under fluctuating loads with changing direction and magnitude or complex loads.

The standard products are made of stainless steel, and a wide range of variations in shapes and sizes are available for selection suitable for each application.

Linear Way L is widely used in such fields as medical equipment, semiconductor manufacturing equipment, and liquid crystal related equipment, where its excellent performance has been proved.

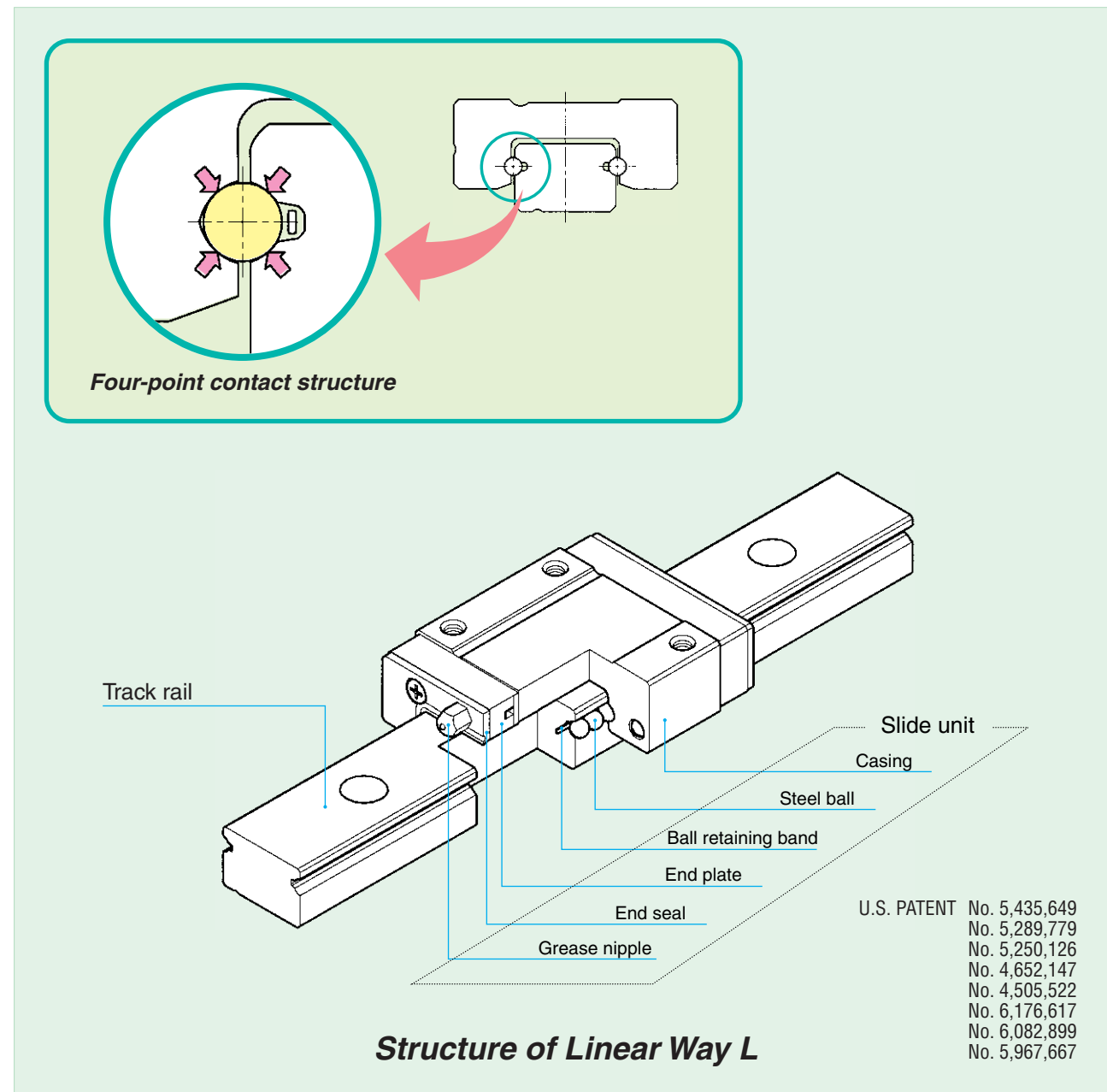

Miniature size

The smallest size models, Linear Way LWL 2 (track rail width: 2 mm) and Linear Way LWLF 4 (wide rail type) have been newly added to the series. These models will contribute to further reduction in size and weight and improvement in performance of equipment.

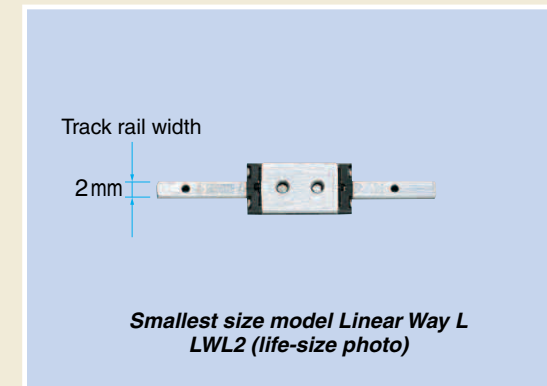

High accuracy achieved by eliminating the number of potential errors

The simple two-row, four-point contact design minimizes the number of potential errors in manufacturing and measurement, so the highest level of dimensional accuracy between rows can be achieved. Interchangeable specification products of high-interchangeability level can be manufactured benefiting from this feature by rigorous control of the dimensional accuracy of individual slide units and track rails.

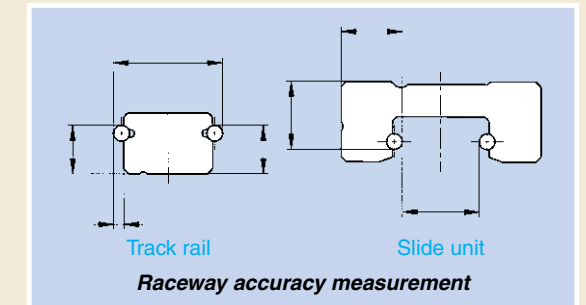

Stainless steel series with excellent corrosion resistance

Stainless steel series Linear Way L has excellent corrosion resistance and is most suitable for machines and equipment used in clean rooms and environments, for example, medical equipment, disk read devices, and semiconductor manufacturing equipment.

Abundant variations

Two types with different section shapes, the standard type and the wide rail type, are available. In each of these types, three types with different lengths are also provided. The wide rail type can support a large moment load acting around the axial direction, and is suitable for single row rail arrangement.

In addition to the standard specification track rail which is fixed by inserting bolts downward in the mounting holes, the tapped rail specification track rail that has tapped screw holes is available, so an optimum mounting direction can be selected, giving more freedom in machine design.

Ball retained type realized in miniature series

The slide unit of ball retained type incorporates ball retaining bands, which prevent steel balls from dropping when the slide unit is separated from the track rail. So mounting on machines and equipment can be made easily.

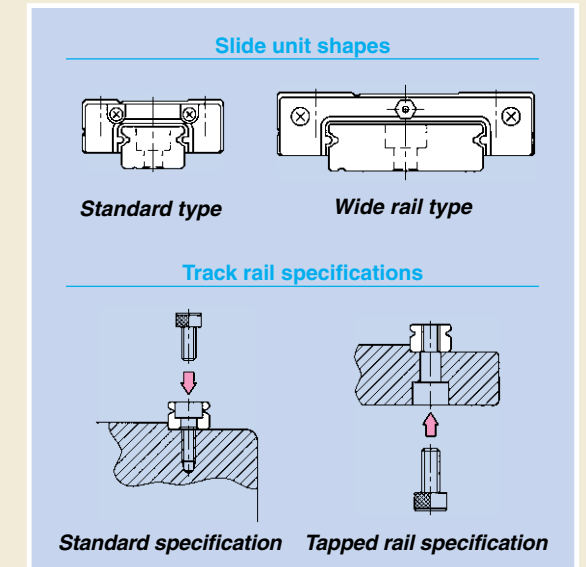
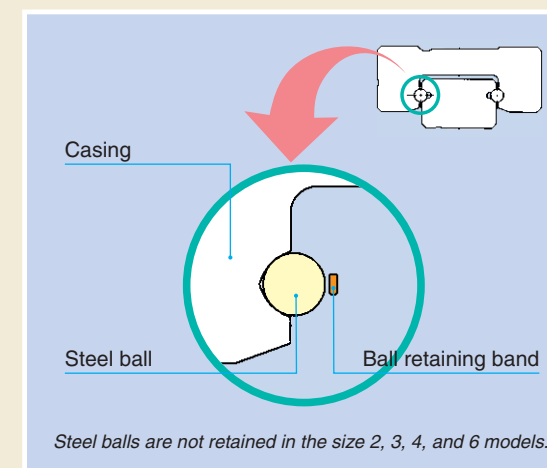

Stainless Steel Series for Special Environment

Stainless steel series Linear Way L, which is more resistant to corrosion than the high carbon steel models, is most suitable for applications in clean rooms and in places where the use of rust preventive oil must be limited or avoided because any oily content is inimical to the environment. Product specifications most suitable for the needs in diversified special environment applications can be provided by combining various special specifications.

Stainless steel end plate

By replacing the standard synthetic resin end plates with stainless steel end plates, Linear Way L can be used in a vacuum environment and its heat resistance can be improved as well. When ordering, indicate this specification in combination with the specification of "with no end seals" (supplemental code "N") or the specification of "with seals for special environment" (supplemental code "/RE").

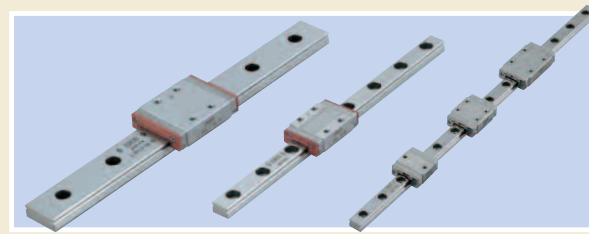

Low-dust-generation grease CG2 for clean environment

When Linear Way L is used in a clean environment, pollution of the clean environment by scattered grease must be avoided.

The low-dust-generation grease for clean environment, which contains the urea base thickener and synthetic base oil, keeps the environmental pollution in clean rooms to the lowest level.



<Identification number> TG120/CG2 (Tube type: Net 120 g)



<Identification number> MG10/CG2 (Miniature greaser type: Net 10 g)

Interchangeable Products, Three Features of Interchangeability

The track rails and the slide units of interchangeable specification Linear Way L can be handled separately and can be assembled to make a set as required. Interchangeability of incomparable high level has been achieved through rigorous dimensional control of the slides units and the track rails on the basis of the original advanced manufacturing technology of IJKO.

Interchangeable slide unit

Three types of slide units with different lengths are prepared. All of these slide units can be freely mounted on the same track rail.

It is also possible to combine a slide unit and track rail of different materials, for example, a high carbon steel slide unit and stainless steel track rail can be combined.

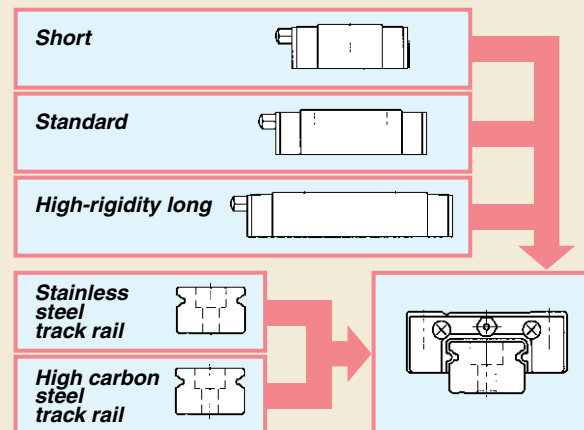

Interchangeable with high accuracy

Two accuracy classes, high class and precision class, are prepared as accuracy classes to satisfy the requirement for high running accuracy. Height variation among multiple sets is also controlled at a high accuracy level, ensuring that these products can be used for parallel track rail arrangement.

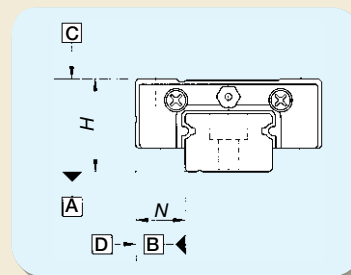

Interchangeable with preload

High accuracy dimensional control owing to a simple structure has made it possible to realize the interchangeability among preloaded slide units. These products can be used for applications requiring one step higher rigidity.

Various Types for Diversified Application Needs

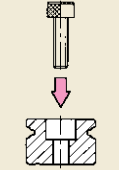
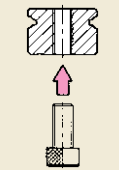
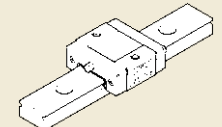
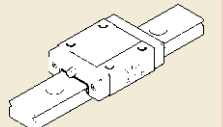
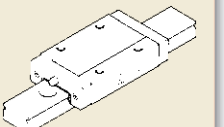
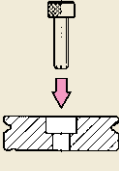
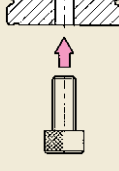
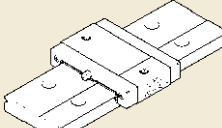
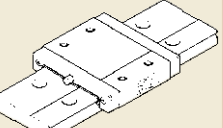
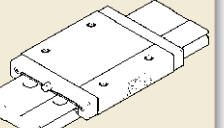
Shape	Track rail specification		Length of slide unit		
	Standard specification	Tapped rail specification	Short	Standard	High-rigidity long
Standard type	 LWL...B	 LWL...N	 LWLC	 LWL	 LWLG
Wide rail type	 LWLF...B	 LWLF...N	 LWLFC	 LWLF	 LWLFG

Abundant Series and Size variations

Shape	Material	Length of slide unit	Track rail specification	Model code	Size
Standard type	Stainless steel made	Short	Standard specification	LWLC ...B	— — 5 7 9 12 15 20 25
			Tapped rail specification	LWLC ...N ⁽¹⁾⁽²⁾	— 3 5 7 9 — — — —
		Standard	Standard specification	LWL ...B	— — 5 7 9 12 15 20 25
			Tapped rail specification	LWL ...N ⁽¹⁾⁽²⁾	2 3 5 7 9 — — — —
		High-rigidity long	Standard specification	LWLG ...B	— — — 7 9 12 15 20 25
			Tapped rail specification	LWLG ...N	— — — 7 9 — — — —
Wide rail type	Stainless steel made	Short	Standard specification	LWLFC ...B ⁽¹⁾⁽³⁾	— 6 10 14 18 24 30 42
			Tapped rail specification	LWLFC ...N ⁽¹⁾	— 6 10 14 18 — — — —
		Standard	Standard specification	LWLF ...B ⁽¹⁾⁽³⁾	4 6 10 14 18 24 30 42
			Tapped rail specification	LWLF ...N ⁽¹⁾	— 6 10 14 18 — — — —
		High-rigidity long	Standard specification	LWLFG ...B	— — — 14 18 24 30 42
			Tapped rail specification	LWLFG ...N	— — — 14 18 — — — —
High carbon steel made	Standard	Standard specification	LWLF ...BCS	— — — — 9 12 15 20 —	
		Standard specification	LWLF ...BCS	— — — — 18 24 30 42	

Note⁽¹⁾: Steel balls are not retained in the size 2, 3, 4, and 6 models.

⁽²⁾: The track rails of size 2 and 3 models are tapped rails, but "N" is not attached to their model codes.

⁽³⁾: For the size 4 and 6 models, "B" is not attached to their model codes.

Remark: Interchangeable specification products are available in the sizes indicated in .

Identification Number

The specification of Linear Way L is indicated by the identification number, which consists of a model code, a size, a part code, a material symbol, a preload symbol, a classification symbol, an interchangeable code, and any supplemental codes.

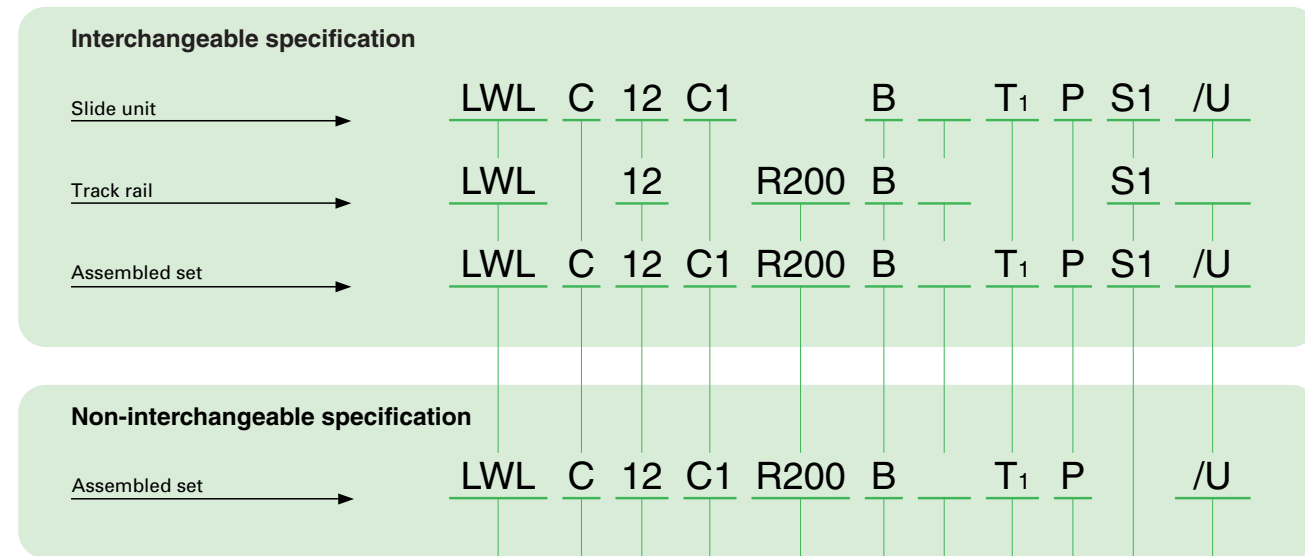

1 Series	Standard type : LWL Wide rail type : LWLF	For applicable models and sizes, see Table 1.
2 Length of slide unit	Short : C Standard : No symbol High-rigidity long : G	For applicable models and sizes, see Table 1.
3 Structure	Ball non-retained type (sizes 2, 3, 4, and 6) : No symbol Ball retained type (except sizes 2, 3, 4, and 6) : B Tapped rail specification : N	For applicable models and sizes, see Table 1.
4 Size of rolling guide		For applicable models and sizes, see Table 1.

Table 1 Models and sizes of Linear Way L

LWL	Material	Model	Size									
			2	3	5	7	9	12	15	20	25	
Stainless steel made	LWLC	LWL	—	○ ⁽¹⁾⁽²⁾	○	○	○	○	○	○	○	○
		LWLG	—	—	—	○	○	○	○	○	○	○
	LWL...CS	—	—	—	—	○	○	○	○	○	—	

LWLF	Material	Model	Size								
			4	6	10	14	18	24	30	42	
Stainless steel made	LWLFC	LWLF	—	○ ⁽¹⁾	○	○	○	○	○	○	○
		LWLF	○ ⁽¹⁾	○ ⁽¹⁾	○	○	○	○	○	○	○
	LWLF	—	—	—	○	○	○	○	○	○	
High carbon steel made	LWLF...CS	—	—	—	—	○	○	○	○	○	

Note⁽¹⁾: In the size 2, 3, 4, and 6 models, steel balls are not retained. Interchangeable specification is not applicable to these models.
⁽²⁾: The track rails of the size 2 and 3 models are of the tapped rail specification, but "N" is not attached to the model code. The standard specification track rail is not available.
 Remark: For the models indicated in [], the tapped rail specification "N" is applicable. For Linear Way L of tapped rail specification, the interchangeable specification is not applicable.

5 Number of slide units	Assembled set : C○ Slide unit : C1	For an assembled set, the number of slide units assembled on one track rail is indicated. For a single slide unit, only "C1" can be indicated.
6 Length of track rail	Assembled set : R○ Track rail : R○	The length of track rail is indicated in mm. For standard and maximum lengths, see Table 17 on pages 17 and 18.
7 Material	Stainless steel made : No symbol High carbon steel made : CS	For applicable models and sizes, see Table 1.
8 Preload amount	Clearance : T ₀ Standard preload : No symbol Light preload : T ₁	Specify this item for an assembled set or a slide unit. Note that the preload amount that can be specified differs depending on the model and size. For details of preload amount, see Table 3 on page 9.
9 Accuracy class	High class : H Precision class : P	Specify this item for an assembled set or a single slide unit. The track rails of interchangeable specification are not classified by the classification symbol. For details of accuracy classes, see Table 2 on page 9.
10 Interchangeable code	S1 specification : S1 S2 specification : S2	Specify this item for the interchangeable specification products. Assemble track rails and slide units with the same interchangeable code. Performance and accuracy of "S1" group and "S2" group are the same.
11 Special specification	/A, /BS, /D, /E, /I, /LR, /N, /Q, /RE, /U, /W○, /Y○	For applicable special specifications, see Table 4 on page 10.

Accuracy

The accuracy of Linear Way L is shown in Table 2.

Table 2 Accuracy

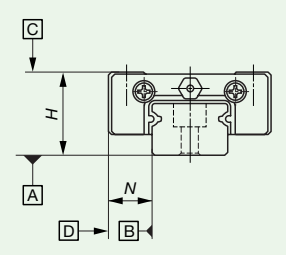

Item	Classification (Symbol)	High (H)	Precision (P)
		High (H)	Precision (P)
Dim. <i>H</i> tolerance		± 0.020	± 0.010
Dim. <i>N</i> tolerance		± 0.025	± 0.015
Dim. variation of <i>H</i> (1)		0.015	0.007
Dim. variation of <i>N</i> (1)		0.020	0.010
Dim. variation of <i>H</i> for multiple assembled sets (2)		0.030	0.020
Parallelism in operation of C to A		See Fig. 1	
Parallelism in operation of D to B		See Fig. 1	

Note(1): It means the size variation between slide units mounted on the same track rail.
 (2): It applies to the interchangeable specification products.

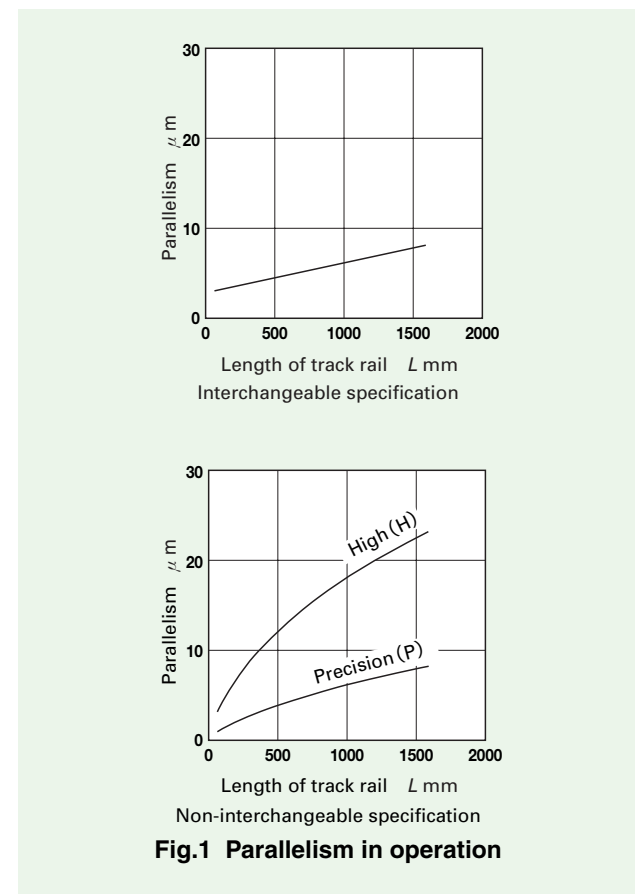

Preload

The average amount of preload for Linear Way L is shown in Table 3.

Table 3 Preload amount

Preload type	Item	Symbol	Preload amount (N)	Application
Clearance	(1)	T ₀	0 (4)	· Very smooth motion
	Standard (2)	(No symbol)	0 (5)	· Smooth and precise motion
Light preload (3)		T ₁	0.02C ₀	· Minimum vibration · Load is equally balanced. · Smooth and precise motion

Note(1): Applicable to the non-interchangeable specification.
 (2): Not applicable to the size 2, 3, 4, and 6 models.
 (3): Not applicable to the size 2, 3, 4, 5, 6, and 10 models.
 (4): Zero or minimal amount of clearance
 (5): Zero or minimal amount of preload
 Remark: C₀ means the basic static load rating.

Special specifications

Linear Way L of the special specifications shown in Table 4 are available.
 When a special specification is required, add the applicable supplemental code to the end of the identification number.

When a combination of several special specifications is required (See Table 5.), arrange their supplemental codes in alphabetical order.

Table 4 Special specifications for Linear Way L

Special specification	Supplemental code	Interchangeable specification			Non-interchangeable specification
		Slide unit	Track rail	Assembled set	
Butt-jointing track rail	/A	—	—	—	○(1)(2)(3)
Stainless steel end plates	/BS	—	—	—	○(4)
Opposite reference surfaces arrangement	/D	—	—	○	○
Specified track rail mounting hole positions	/E	—	○	○	○
Inspection sheet	/I	—	—	—	○
Black chrome surface treatment (track rail)	/LR	—	—	—	○(2)(5)
No end seal	/N	○	—	○	○(3)
Capillary plate	/Q	○	—	○	○(3)
Seal for special environment	/RE	—	—	—	○(4)
Track rail with stopper pins	/S	—	—	—	○(3)
Under seals	/U	○(6)	—	○(6)	○(6)
Matched sets to be used as an assembled group	/W	—	—	—	○
Specified grease	/Y	—	—	—	○

Note(1): Not applicable to the high carbon steel specification.
 (2): Not applicable to the tapped rail specification.
 (3): Not applicable to the size 2, 3, 4, and 6 models.
 (4): Not applicable to the size 2, 3, 4, 6, and 25 models.
 (5): Not applicable to the size 2, 3, 4, 5, 6, and 10 models.
 (6): Not applicable to the size 2, 3, 4, 5, 6, 7, 10, and 14 models.

Table 5 Combination of special specifications

BS	○											
D	○	○										
E	—	○	—									
I	○	○	○	○								
LR	—	○	○	○	○							
N	○	○	○	○	○	○						
Q	○	○	○	○	○	○	○					
RE	○	○	○	○	○	○	○	○				
S	○	○	○	○	○	○	○	○	○			
U	○	○	○	○	○	○	○	○	○	○		
W	○	○	○	○	○	○	○	○	○	○	○	
Y	○	○	○	○	○	○	○	○	○	○	○	○
	A	BS	D	E	I	LR	N	Q	RE	S	U	W

Remark: The specifications marked ○ in this table can be combined.

Butt-jointing track rails /A

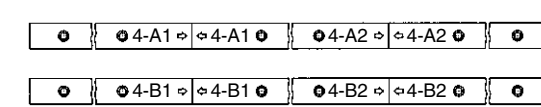

When the required length of stainless steel non-interchangeable specification track rail exceeds the maximum length shown in Table 17, two or more track rails can be used by butt-jointing them in the direction of linear motion. For the length and the number of butt-jointing track rails, consult  for further information.

Opposite reference surfaces arrangement /D

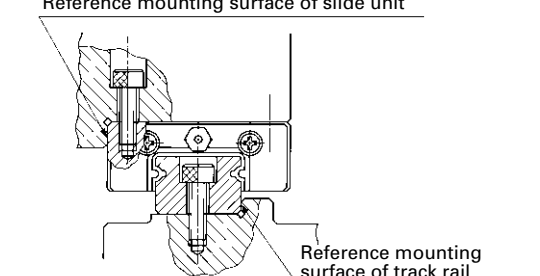

The reference mounting surface of track rail is made opposite to the standard side. The accuracy of dimension N including parallelism in operation is the same with that of standard specification.

With stainless steel end plates /BS

The standard synthetic resin end plates are replaced with stainless steel end plates, keeping the total length of the slide unit unchanged. When superior heat resistance is required, it is recommended to apply this specification in combination with the "with seal for special environment (supplemental code /RE)" or "with no end seal (supplemental code /N)" specification.

Specified track rail mounting hole positions /E

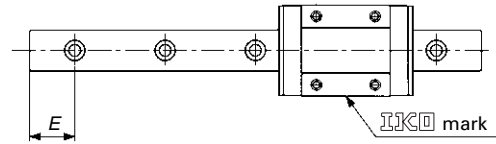

The mounting hole positions of track rail can be specified by specifying dimension E at the left end, which is the distance from the mounting hole nearest to the left end of the track rail to the left end face of the track rail in sight of mark on the slide unit. When ordering, add the dimension (in mm) after "/E". Dimension E can be specified in a limited range. Consult for further information.

Capillary plate /Q

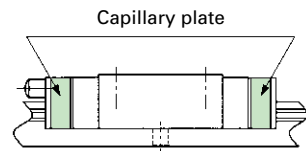

The capillary plate is assembled inside the end seal of the slide unit. It is impregnated with lubricant so that the re-lubrication interval can be made longer. For the total length of the slide unit with capillary plates see Table 6.

Track rail with stopper pins /S

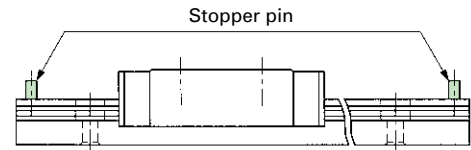

To prevent the slide unit of Linear Way L from slipping off, stopper pins are provided at both ends of the track rail. For dimensions of the track rail with stopper pins, see Table 7.

Specified grease /YCG /YBR /YNG

The type of prepacked grease in the slide unit can be changed by a supplemental code. The size 2 and 4 models are not applicable /YCG and /YBR specifications.

- ① /YCG low-dust-generation grease for clean environment CG2 is prepacked.
- ② /YBR MOLYCOTE BR2 Plus Grease (Dow Corning) is prepacked.
- ③ /YNG No grease is prepacked.

Inspection sheet /I

The inspection sheet recording dimensions H and N , dimensional variations of H and N , and parallelism in operation of the slide unit is attached to each set.

Black chrome surface treatment /LR

After a black permeable chrome film is formed on the track rail by treatment, acrylic resin is coated to improve the corrosion resistance.

No end seal /N

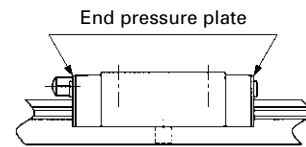

End seals at both ends of slide unit are replaced with end pressure plates that are not in contact with the track rail to reduce frictional resistance. The under seals are not assembled. This specification is not effective for dust protection.

Seal for special environment /RE

The standard end seals are changed into seals for special environment that can be used at high temperature.

With under seals /U

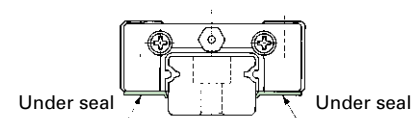

To prevent foreign substances from intruding from the lower side of Linear Way, seals are provided on the bottom faces of slide unit. For size H_1 , see Table 8.

Matched sets to be used as an assembled group /W

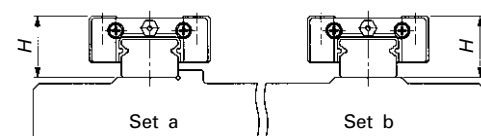

For two or more sets of Linear Way L used on the same plane, the dimensional variation of H of Linear Way L is kept within the specified range. The dimensional variation of dimension H in matched sets is the same as that in a single set. When ordering, indicate the number of sets, which is always represented by the number of track rails, after "/W".

Table 6 Dimensions of slide unit with capillary plates (Supplemental code: /Q)

unit: mm					
Model number	L_1	L_4	Model number	L_1	L_4
LWLC 5...B	22	—	LWLFC 10...B	26.5	—
LWL 5...B	25	—	LWLFC 10...B	30.5	—
LWLC 7...B	27	—	LWLFC 14...B	30.5	—
LWL 7...B	31.5	—	LWLFC 14...B	39.5	—
LWLG 7...B	39	—	LWLFC 14...B	50	—
LWLC 9...B	30	—	LWLFC 18...B	34.5	—
LWL 9...B	39	—	LWLFC 18...B	47	—
LWLG 9...B	49	—	LWLFC 18...B	58.5	—
LWLC 12...B	33	—	LWLFC 24...B	38.5	—
LWL 12...B	42	—	LWLFC 24...B	52	—
LWLG 12...B	52	—	LWLFC 24...B	67	—
LWLC 15...B	42	46	LWLFC 30...B	45.5	50
LWL 15...B	52	57	LWLFC 30...B	60	64
LWLG 15...B	67	72	LWLFC 30...B	78.5	83
LWLC 20...B	48	52	LWLFC 42...B	51.5	56
LWL 20...B	60	65	LWLFC 42...B	65	70
LWLG 20...B	78	82	LWLFC 42...B	84.5	89
LWLC 25...B	63.5	74			
LWL 25...B	87.5	98			
LWLG 25...B	107.5	118			

Remark: The above table shows representative model numbers but is applicable to all models of the same size.

Table 7 Dimensions of track rail with stopper pins (Supplemental code /S)

unit: mm							
Model number	a	b	c	Model number	a	b	c
LWL 5...B	2	2	1.6	LWLF 10...B	2	2	1.6
LWL 7...B	2.5	3	2	LWLF 14...B	2.5	3	2
LWL 9...B				LWLF 18...B			
LWL 12...B				LWLF 24...B			
LWL 15...B				LWLF 30...B			
LWL 20...B				LWLF 42...B			
LWL 25...B	3.5						

Remark: The above table shows representative model numbers but is applicable to all models of the same size. This table is not applicable to the interchangeable specification.

Table 8 Dimension H_1 of slide unit with under seals (Supplemental code /U)

unit: mm			
Model number	H_1	Model number	H_1
LWL 9...B	1	LWLF 18...B	2
LWL 12...B	2	LWLF 24...B	
LWL 15...B	3	LWLF 30...B	
LWL 20...B	4	LWLF 42...B	3
LWL 25...B	5 ⁽¹⁾		

Note⁽¹⁾: This dimension is the same as that without under seals. Remark: The above table shows representative model numbers but is applicable to all models of the same size.

Load Rating and Life

Basic dynamic load rating C

The basic dynamic load rating is defined as the constant load in both direction and magnitude under which a group of identical Linear Ways are individually operated and 90% of those in the group can travel 50×10^3 meters free from material damage due to rolling contact fatigue.

Basic static load rating C_0

The basic static load rating is defined as the static load that gives a prescribed constant contact stress at the center of the contact area between the rolling element and raceway receiving the maximum load. It is the allowable limit load that permits normal rolling motion. Generally, the basic static load rating is used in combination with the static safety factor.

Static moment rating T_0, T_x, T_y

The static moment rating is defined as the static moment load that gives a prescribed constant contact stress at the center of the contact area between the rolling element and raceway receiving the maximum load when a moment (See Fig. 3.) is loaded. It is the allowable limit moment that permits normal rolling motion. Generally, the static moment rating is used in combination with the static safety factor.

Load direction and load rating

Since the load ratings of Linear Way L given in the table of dimensions are for upward/downward load, they must be corrected for the load direction for lateral load. The corrected

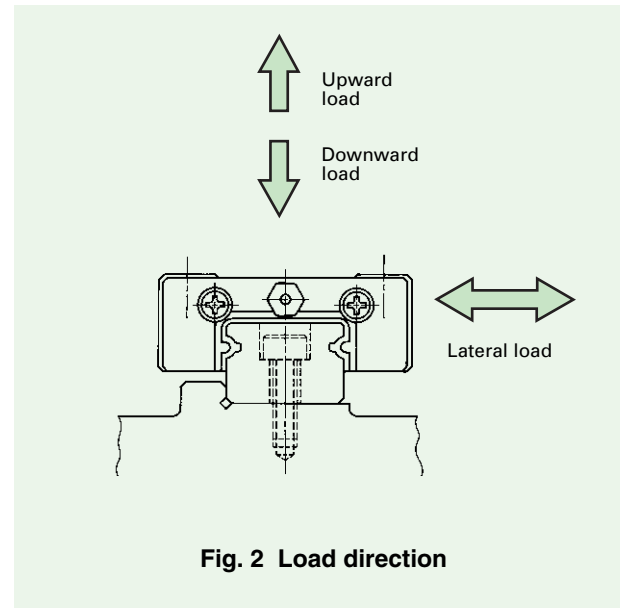

Fig. 2 Load direction

Table 9 Load ratings corrected for the load direction

Load direction	Upward/downward direction		Lateral direction	
	Basic dynamic load rating	Basic static load	Basic dynamic load rating	Basic static load
Size				
2, 3, 4, 6	C	C_0	$1.13C$	$1.19C_0$
Other than 2, 3, 4, 6	C	C_0	$0.88C$	$0.84C_0$

basic dynamic load ratings and basic static load ratings are shown in Table 9.

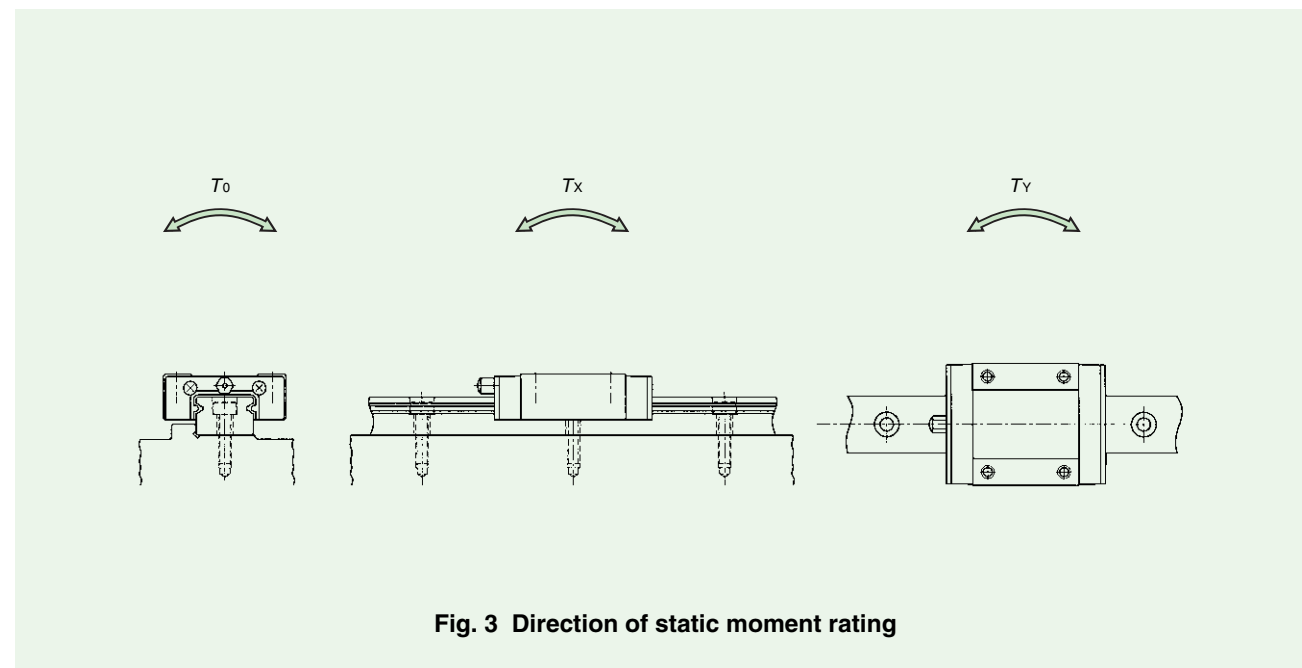

Fig. 3 Direction of static moment rating

Life

The rating life of Linear Way L can be calculated by the following formula.

$$L = 50 \left(\frac{C}{P} \right)^3 \dots\dots\dots (1)$$

where, L : Rating life, 10^3m
 C : Basic dynamic load rating, N
 P : Applied load, N

Accordingly, when the stroke length and the number of strokes per minute are given, the life in hours can be calculated from the following formula.

$$L_h = \frac{10^6 L}{2S n_1 \times 60} \dots\dots\dots (2)$$

where, L_h : Rating life in hours, h
 S : Stroke length, mm
 n_1 : Number of strokes per minute, cpm

Static safety factor

The static safety factor of Linear Way L can be calculated by the following formula.

$$f_s = \frac{C_0}{P_0} \dots\dots\dots (3)$$

where, f_s : Static safety factor
 C_0 : Basic static load rating, N
 P_0 : Applied load (maximum load), N

Table 10 Static safety factor

Operating conditions	f_s
Operation with vibration and/or shocks	3 ~ 5
High operating performance	2 ~ 4
Normal operation	1 ~ 3

Load factor

Due to vibration and/or shocks during machine operation, the actual load on each rolling guide becomes greater in many cases than the theoretically calculated load. The applied load is generally calculated by multiplying the theoretically calculated load by the load factor indicated in Table 11.

Table 11 Load factor

Operating conditions	f_w
Smooth operation free from vibration and/or shocks	1 ~ 1.2
Normal operation	1.2 ~ 1.5
Operation with vibration and/or shocks	1.5 ~ 3

Lubrication

Lithium-soap base grease (MULTEMP PS No.2 (KYODO YUSHI)) is pre-packed in Linear Way L. However, as the quality of any grease will gradually deteriorate as operating time passes, periodic relubrication is necessary. The relubrication interval varies depending on the operating conditions of the rolling guides. A six month interval is generally recommended, and, if the machine operation consists of reciprocating motions with many cycles and long strokes, relubrication every three months is recommended.

Linear Way L is provided with an oil hole shown in Table 12 or a grease nipple shown in Table 13. The size 2, 3, 4, and 6 models are not provided with an oil hole. For lubrication of these models, apply grease directly to the raceways of the track rail. Supply nozzles matching the size of grease nipples and special grease injectors (miniature greaser) matching the size of oil holes are available. For these parts for lubrication, consult for further information.

The capillary plate of special specification (supplemental code "/Q") can be used to extend the relubrication interval and greatly reduce the maintenance work including grease-replenishment.

Table 12 Oil hole

Identification number	Oil hole size		
	d_1	d_2	
LWL 5...B	LWLF 10...B	0.5	1.1
LWL 7...B	LWLF 14...B		1.2
LWL 9...B	LWLF 18...B		1.5
LWL 12...B	LWLF 24...B		2

Remark: The above table shows representative model numbers but is applicable to all models of the same size.

Table 13 Grease nipple

Identification number	Type	Dimensions and shape
LWL 15...B LWL 20...B	LWLF 30...B LWLF 42...B	A-M3 Width across flats 4 M3
LWL 25...B	—	B-M4 67.5° 2.1 6 6 10 Width across flats 6 M4



Remark: The above table shows representative model numbers but is applicable to all models of the same size.

Precautions for Use

1 Mounting surface, reference mounting surface, and general mounting structure

To mount Linear Way L, correctly fit the reference mounting surfaces B and D of the slide unit and the track rail to the reference mounting surfaces of the table and the bed, and then fix them tightly. (See Fig. 4.)

The reference mounting surfaces B and D and mounting surfaces A and C of Linear Way L are accurately finished by grinding. Stable and high accuracy linear motion can be obtained by finishing the mating mounting surfaces of machines or equipment with high accuracy and correctly mounting the guide on these surfaces.

The slide unit reference mounting surface is always the side surface opposite to the  mark. The track rail reference mounting surface is identified by locating the  mark on the top surface of the track rail. The track rail reference mounting surface is the side surface above the  mark (in the direction of the arrow). (See Fig. 5.)

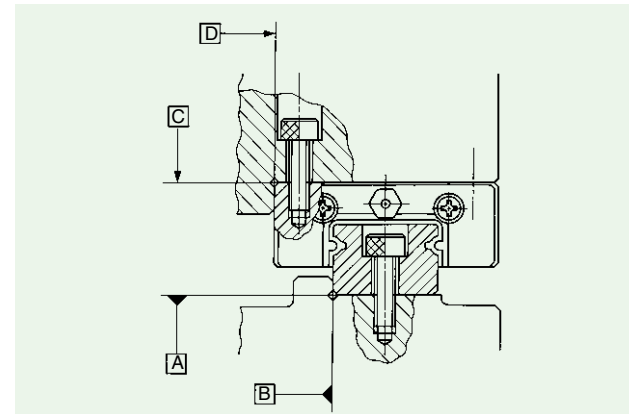

Fig. 4 Reference mounting surfaces and general mounting structure

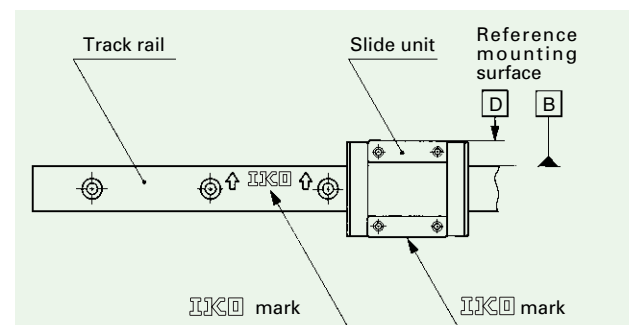

Fig. 5 Reference mounting surfaces

2 Mounting bolts of the slide unit

For the size 2, 3, 4, and 6 models, the female threads for mounting the slide unit are through thread holes. If the fixing depth of the mounting bolts is too long, the bolts will interfere with the track rail, resulting in poor traveling accuracy and short life. The fixing depth of the mounting bolts should be kept within the values shown in the table of dimensions.

3 Mounting bolts of the track rail

For the tapped rail specification models, mounting bolts for track rail are not attached. Prepare bolts with a fixing depth not exceeding the length H4 in the table of dimensions.

4 Corner radius and shoulder height of reference mounting surfaces

It is recommended to make a relieved fillet at the corner of the mating reference mounting surfaces as shown in Fig. 4. Table 14 shows recommended shoulder heights of the mating reference mounting surfaces.

Table 14 Shoulder heights of the mating reference mounting surfaces

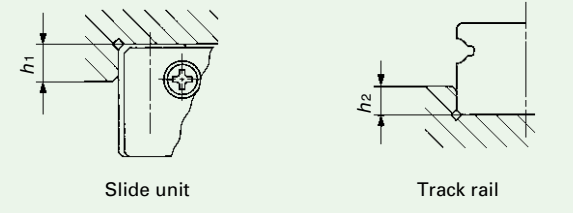

unit: mm

Model number	Slide unit shoulder height h_1	Track rail (1) shoulder height h_2
LWL 2	—	0.5
LWL 3	LWLF 4	0.8
—	LWLF 6	0.8
LWL 5...B	—	0.8
—	LWLF 10...B	1.2
LWL 7...B	LWLF 14...B	1.2
LWL 9...B	—	1.5
—	LWLF 18...B	2.5
LWL 12...B	LWLF 24...B	2.5
—	LWLF 30...B	2.5
LWL 15...B	—	3
—	LWLF 42...B	3
LWL 20...B	—	4
LWL 25...B	—	4

Note(1): For "with under seals" (supplemental code "/U"), it is recommended to use a value obtained by subtracting 1 mm from the value shown in the table. However, for "with under seals" of the size 9 models, 0.8 mm is recommended.

Remark: The above table shows representative model numbers but is applicable to all models of the same size.

Remark: The above table shows representative model numbers but is applicable to all models of the same size.

5 Multiple slide units mounted in close distance

When using multiple slide units in close distance to each other, actual load may be greater than the calculated load depending on the mounting accuracy of the slide units on the mounting surfaces and the reference mounting surfaces of the machine. It is suggested in such cases to assume a greater load than the calculated load.

6 Operating temperature

The maximum operating temperature is 120 °C and a continuous operation is possible at temperatures up to 100 °C. When the temperature exceeds 100 °C, consult . For the "with capillary plate" (supplemental code "/Q") of special specification, operate Linear Way L below 80 °C.

Mounting

1 When mounting multiple sets at the same time

In the case of interchangeable specification Linear Way L, assemble a slide unit and a track rail with the same interchangeable code ("S1" or "S2").

In the case of non-interchangeable specification Linear Way L, use an assembly of slide unit and track rail as delivered without changing the combination.

In the case of matched sets to be used as an assembled group, special specification products of matched sets (supplemental code "/W") are delivered as a group in which dimensional variations are specially controlled. Mount them without mixing with the sets of another group.

2 Assembling a slide unit and a track unit

When assembling Linear Way L, correctly fit the grooves of the slide unit mounted on a dummy rail (steel ball holder) to the grooves of the track rail, and then move the slide unit gently in parallel direction.

Steel balls are retained in Linear Way L Ball Retained type (except sizes 2, 3, 4, and 6), so the slide unit can be separated freely from the track rail. However, the slide unit can be assembled on the track rail much easier by using the dummy rail (steel ball holder).

In Linear Way L Non-Ball Retained type (sizes 2, 3, 4, and 6), steel balls are not retained. When separating the slide unit from the track rail, a dummy rail (steel ball holder) should be used.

The slide unit of Linear Way L of interchangeable specification is already assembled on a dummy rail (steel ball holder). The steel ball holder is appended as an accessory to models shown in Table 15. The steel ball holders for other models are also available. If required, consult  for further information.

Table 15 Models to which a steel ball holder is appended

Standard type	Wide rail type
LWL 2	LWLF 4
LWLC 3 LWL 3	LWLF 6 LWLF 6
LWLC 5...B LWL 5...B	LWLF 10...B LWLF 10...B
LWLC 7...B LWL 7...B LWLG 7...B	LWLF 14...B LWLF 14...B LWLF 14...B
LWLC 9...B LWL 9...B LWLG 9...B	LWLF 18...B LWLF 18...B LWLF 18...B
LWLG 12...B	LWLF 24...B
LWLG 15...B	LWLF 30...B
LWLG 20...B	LWLF 42...B
LWLG 25...B	—

Remark: The above table shows representative model numbers but is applicable to all models of the same size.

3 Cleaning of mounting surfaces

When mounting Linear Way L, remove burrs and blemishes from the mounting surfaces and reference mounting surfaces of machines and equipment and wipe off the rust preventive oil and foreign substances with clean cloth.

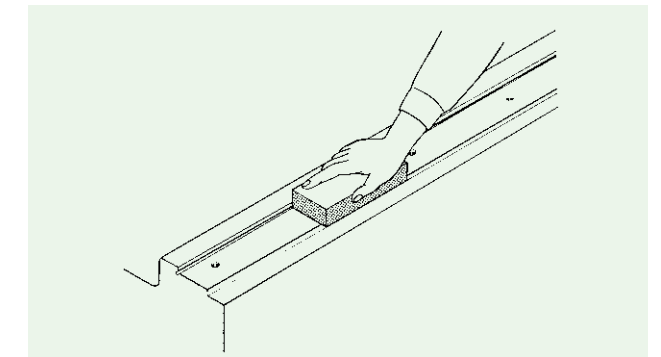

Fig. 6 Cleaning of mounting surfaces

4 Tightening torque of mounting bolts

The standard torque values for mounting Linear Way L on the mating steel made member are shown in Table 16. When machines or equipment are subjected to severe vibration, shock, large fluctuating load, or moment load, the bolts should be tightened with a torque 1.2 to 1.5 times higher than the standard torque values shown. When the mating member material is cast iron or aluminum, tightening torque should be lowered in accordance with the strength characteristics of the material.

Table 16 Tightening torque of mounting bolts

Bolt size	Tightening torque N·m	
	Stainless steel bolt (Property division A2-70)	Carbon steel bolt (Strength division 12.9)
M1 × 0.25	0.04	—
M1.4 × 0.3	0.1	—
M1.6 × 0.35	0.15	—
M2 × 0.4	0.31	—
M2.5 × 0.45	0.62	—
M3 × 0.5	1.1	1.2
M4 × 0.7	2.5	2.8
M5 × 0.8	5.0	5.6
M6 × 1.0	8.5	—

Track Rail Length

Standard and maximum lengths of track rails are shown in Table 17. Track rails in any length are also available. Simply indicate the necessary length of track rail in mm in the identification number.

For stainless steel non-interchangeable track rails longer than the maximum length shown in Table 17.1, butt-jointing track rails are available upon request. In this case, indicate "/A" in

the identification number.

E dimensions at both ends are the same unless otherwise specified. To change these dimensions, specify the specified rail mounting hole positions (supplemental code "/E") of special specification.

Table 17.1 Standard and maximum lengths of stainless steel track rails

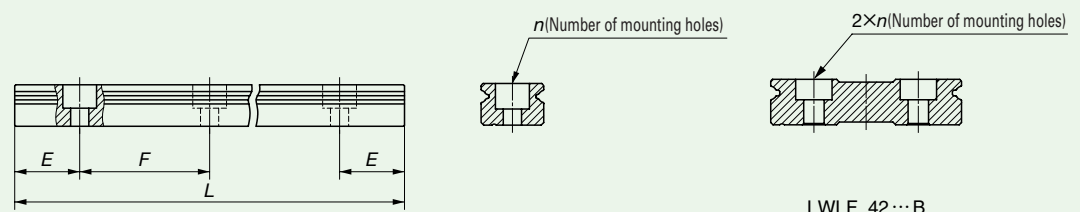

Model number	LWL 2	LWL 3	LWL 5...B LWL 5...N	LWL 7...B LWL 7...N	LWL 9...B LWL 9...N	LWL 12...B	LWL 15...B	LWL 20...B	LWL 25...B
Standard length $L(n)$	32(4) 40(5) 56(7) 80(10)	30(3) 40(4) 60(6) 80(8) 100(10)	60(4) 90(6) 105(7) 120(8) 150(10)	60(4) 90(6) 120(8) 150(10) 180(12) 240(16)	60(3) 80(4) 120(6) 160(8) 220(11) 280(14)	100(4) 150(6) 200(8) 275(11) 350(14) 475(19)	160(4) 240(6) 320(8) 440(11) 560(14) 680(17)	180(3) 240(4) 360(6) 480(8) 660(11) 840(14)	240(4) 300(5) 360(6) 480(8) 660(11) 900(15)
Pitch of mounting holes F	8	10	15	15	20	25	40	60	60
E	4	5	7.5	7.5	10	12.5	20	30	30
Maximum length ⁽¹⁾	104	150 (200)	210 (300)	300 (390)	860 (960)	1 000 (1 200)	1 000 (1 200)	960 (1 200)	960 (1 200)
Maximum number of butt-jointing track rails	—	—	5	7	2	2	2	2	2
Maximum length of butt-jointing track rails	—	—	915	1 905	1 660	1 925	1 880	1 740	1 740

Model number	LWLF 4	LWLF 6 LWLF 6...N	LWLF 10...B LWLF 10...N	LWLF 14...B LWLF 14...N	LWLF 18...B LWLF 18...N	LWLF 24...B	LWLF 30...B	LWLF 42...B
Standard length $L(n)$	40(4) 60(6) 70(7) 80(8) 100(10)	60(4) 90(6) 105(7) 120(8) 150(10)	60(3) 80(4) 120(6) 160(8) 220(11) 280(14)	90(3) 120(4) 150(5) 180(6) 240(8) 300(10)	90(3) 120(4) 150(5) 180(6) 240(8) 300(10)	120(3) 160(4) 240(6) 320(8) 400(10) 480(12)	160(4) 240(6) 320(8) 440(11) 560(14) 680(17)	160(4) 240(6) 320(8) 440(11) 560(14) 680(17)
Pitch of mounting holes F	10	15	20	30	30	40	40	40
E	5	7.5	10	15	15	20	20	20
Maximum length ⁽¹⁾	180	240 (300)	300 (400)	300 (600)	690 (960)	680 (1 000)	680 (1 000)	680 (1 000)
Maximum number of butt-jointing track rails	—	—	7	8	3	3	3	3
Maximum length of butt-jointing track rails	—	—	1 840	1 950	1 920	1 840	1 840	1 840

Note(1): The track rails can be manufactured up to the maximum lengths shown in parentheses. If required, consult  for further information.

Remarks 1. The above table shows representative model numbers but is applicable to all stainless steel track rails of the same size.

- " Butt-jointing track rails" (supplemental code "/A") specification applies to the track rails of non-interchangeable specification but does not apply to those of tapped rail specification.

Table 17.2 Standard and maximum lengths of high carbon steel track rails

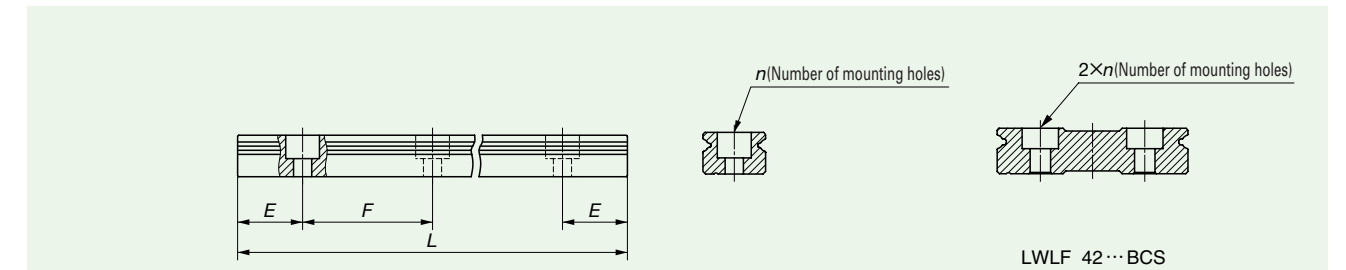

Model number	LWL 9...BCS	LWL 12...BCS	LWL 15...BCS	LWL 20...BCS
Standard length $L(n)$	80(4) 160(8) 220(11) 280(14) 380(19) 500(25) 600(30)	100(4) 200(8) 275(11) 350(14) 475(19) 600(24) 700(28)	160(4) 320(8) 440(11) 560(14) 680(17) 800(20) 920(23)	180(3) 240(4) 360(6) 480(8) 660(11) 900(15) 1020(17)
Pitch of mounting holes F	20	25	40	60
E	10	12.5	20	30
Maximum length	1 000	1 500	1 520	1 560

Model number	LWLF 18...BCS	LWLF 24...BCS	LWLF 30...BCS	LWLF 42...BCS
Standard length $L(n)$	90(3) 180(6) 240(8) 300(10) 420(14) 510(17) 600(20)	120(3) 240(6) 320(8) 400(10) 600(15) 720(18) 800(20)	160(4) 320(8) 440(11) 560(14) 680(17) 800(20) 920(23)	160(4) 320(8) 440(11) 560(14) 680(17) 800(20) 920(23)
Pitch of mounting holes F	30	40	40	40
E	15	20	20	20
Maximum length	1 500	1 520	1 600	1 600

unit: mm

IKO Linear Way L: Standard type
LWLC, LWL, LWLG

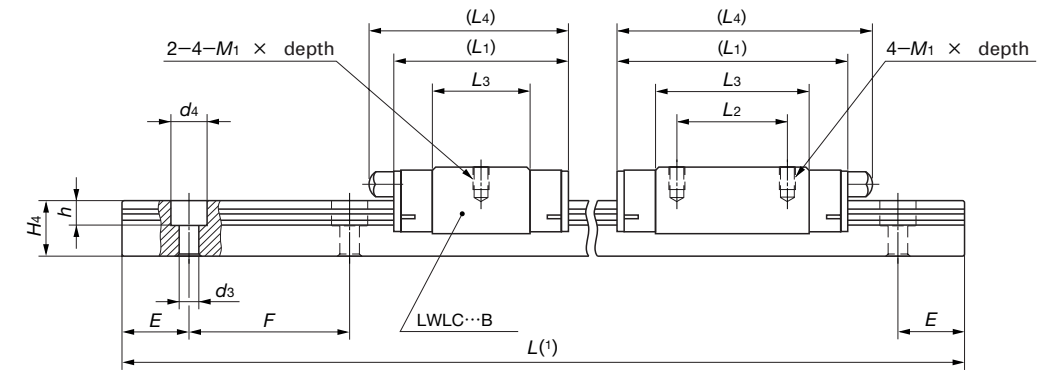
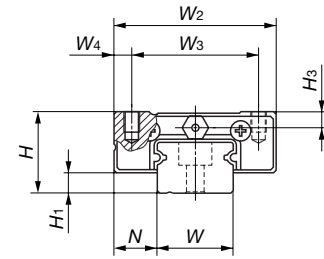

Model number	Interchangeable	Mass (Ref.) g		Dimensions of assembly mm			Dimensions of slide unit mm									
		Slide unit	Track rail (per 100 mm)	H	H ₁	N	W ₂	W ₃	W ₄	L ₁	L ₂	L ₃	L ₄	M ₁ × depth	H ₃	W
LWLC 12...B	☆	22	65	13	3	7.5	27	20	3.5	25	—	13	—	M3 × 3.5	2.7	12
LWL 12...B	☆	35								34	15	21.6				
LWL 12...BCS	☆	51								44	20	32				
LWLG 12...B	☆	51	107	16	4	8.5	32	25	3.5	32	—	17.7	36	M3 × 4	3.1	15
LWLC 15...B	☆	42								42	20	27.8	47			
LWL 15...B	☆	64								57	25	42.7	62			
LWL 15...BCS	☆	95	156	20	5	10	40	30	5	38	—	22.3	42	M4 × 6	4.2	20
LWLC 20...B	☆	89								50	25	34.6	55			
LWL 20...B	☆	133								68	30	52.3	72			
LWL 20...BCS	☆	196	243	25	5	12.5	48	35	6.5	55	—	31.9	65	M6 × 7	5	23
LWLC 25...B	☆	190								78	35	55.7	89			
LWL 25...B	☆	310								98	40	75.5	108			
LWLG 25...B	☆	413														

Dimensions of track rail mm						Appended mounting bolt for track rail mm Bolt size × ℓ	Basic dynamic load rating ⁽²⁾ C N	Basic static load rating ⁽²⁾ C ₀ N	Static moment rating ⁽²⁾			Model number
H ₄	d ₃	d ₄	h	E	F				T ₀ N-m	T _x N-m	T _y N-m	
8	3.5	6.5	4.5	12.5	25	M3 × 8	2 000	2 470	15.3	5.5 43.3	4.7 36.3	LWLC 12...B
							2 960	4 450	27.6	16.0 96.6	13.4 81.1	LWL 12...B
							3 780	6 430	39.9	31.8 174	26.7 146	LWLG 12...B
10	3.5	6.5	4.5	20	40	M3 × 10	3 120	4 040	31.1	12.1 87.6	10.2 73.5	LWLC 15...B
							4 390	6 730	51.8	30.8 178	25.9 149	LWL 15...B
							5 750	10 100	77.7	66.2 351	55.6 294	LWLG 15...B
11	6	9.5	5.5	30	60	M5 × 14	4 070	5 490	56.0	20.2 138	16.9 116	LWLC 20...B
							5 830	9 420	96.1	54.6 291	45.8 244	LWL 20...B
							7 350	13 300	136	106 549	88.9 461	LWLG 20...B
15	7	11.0	9.0	30	60	M6 × 16	8 000	11 000	132	59.5 387	49.9 324	LWLC 25...B
							11 600	19 200	232	169 919	142 771	LWL 25...B
							14 200	26 100	315	304 1 530	255 1 290	LWLG 25...B

Note⁽¹⁾: Track rail lengths L are shown in Table 17.

⁽²⁾: The directions of basic dynamic load rating (C), basic static load rating (C₀), and static moment rating (T₀, T_x, and T_y) are shown in the sketches below.

The upper values in the T_x and T_y columns apply to one slide unit, and the lower values apply to two slide units in close contact.

- Remarks
- The mark ☆ indicates that interchangeable specification products are available.
 - The appended bolts for mounting track rails are hexagon socket head bolts of JIS B 1176 or equivalent, or cross recessed head screws for precision equipment. For stainless steel series Linear Way L, stainless steel bolts or screws are appended.
 - An oil hole is provided for LWLC 12...B, LWL 12...B, LWL 12...BCS, and LWLG 12...B.

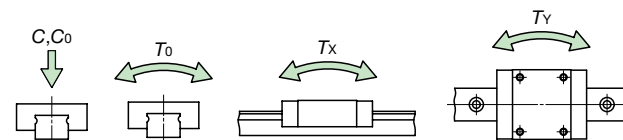

Example of identification number of assembled set

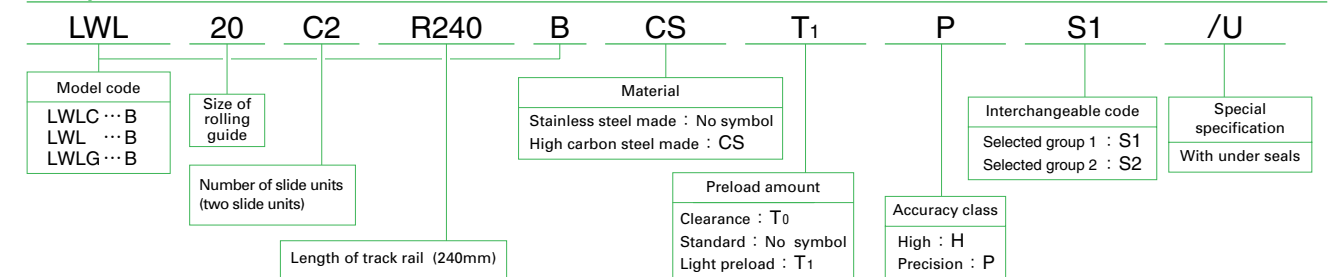

IKO Linear Way L: Wide rail type
LWLFC, LWLF, LWLFG

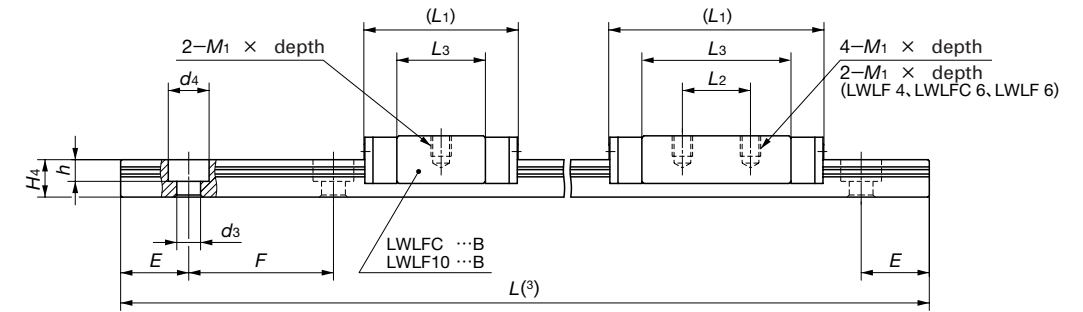
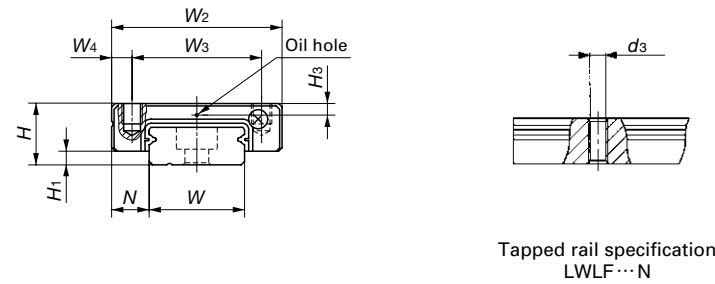

Model number	Interchangeable	Mass (Ref.) g		Dimensions of assembly mm			Dimensions of slide unit mm								Model number
		Slide unit	Track rail (per 100 mm)	H	H ₁	N	W ₂	W ₃	W ₄	L ₁	L ₂	L ₃	M ₁ × depth	H ₃	
LWLF 4 ⁽¹⁾		2.1	6.8	4	1	3	10	—	5	17	6.5	11.9	M2 × 1.3	—	4
LWLFC 6 ⁽¹⁾		2.4	13	4.5	1	3	12	—	6	15	4.5	9.8	M2 × 1.6	—	6
LWLFC 6...N ⁽¹⁾	12														
LWLF 6 ⁽¹⁾		3.4	13	20	8	14.6	20.5	—	13.6	24.5	17.6	M2.5 × 1.5	1.3	10	
LWLF 6...N ⁽¹⁾	12														
LWLFC 10...B	☆	5.9	28	6.5	1.5	3.5	17	13	2	20.5	—	13.6	M2.5 × 1.5	1.3	10
LWLFC 10...N			29												
LWLF 10...B	☆	7.5	28	24.5	17.6	22.5	—	13	M3 × 3	1.7	14				
LWLF 10...N			29												
LWLFC 14...B	☆	13	54	9	2	5.5	25	19	3	31.5	10	22	M3 × 3	1.7	14
LWLFC 14...N			56												
LWLF 14...B	☆	21	54	42	19	32.5	26.5	—	16.6	39	12	28.6	M3 × 3	2.5	18
LWLF 14...N			56												
LWLFG 14...B	☆	31	54	21	4.5	39	12	28.6	M3 × 3	2.5	18				
LWLFG 14...N			56												
LWLFC 18...B	☆	26	90	12	3	6	30	23	3.5	50.5	24	40.4	M3 × 3	2.5	18
LWLFC 18...N			92												
LWLF 18...B	☆	44	90	23	3.5	50.5	24	40.4	M3 × 3	2.5	18				
LWLF 18...N			92												
LWLF 18...BCS	☆	61	90	23	3.5	50.5	24	40.4	M3 × 3	2.5	18				
LWLFG 18...B	☆		90												
LWLFG 18...N		92													

Dimensions of track rail mm						Appended mounting bolt for track rail mm Bolt size × ℓ	Basic dynamic load rating ⁽⁴⁾ C N	Basic static load rating ⁽⁴⁾ C ₀ N	Static moment rating ⁽⁴⁾			Model number
H ₄	d ₃	d ₄	h	E	F				T ₀ N-m	T _x N-m	T _y N-m	
2.6	1.8	2.8	0.75	5.0	10	Cross recessed head screw for precision equipment M1.6 × 5	373	703	1.5	1.3 7.3	1.6 8.7	LWLF 4 ⁽¹⁾
2.8	2.4	4	1.5	7.5	15	Cross recessed head screw for precision equipment M2 × 4	321	562	1.7	0.87 5.3	1.0 6.3	LWLFC 6 ⁽¹⁾
	M 3 Through	—	—			(not appended) ⁽²⁾						LWLFC 6...N ⁽¹⁾
2.8	2.4	4	1.5	7.5	15	Cross recessed head screw for precision equipment M2 × 4	421	843	2.6	1.9 10.2	2.2 12.2	LWLF 6 ⁽¹⁾
	M 3 Through	—	—			(not appended) ⁽²⁾						LWLF 6...N ⁽¹⁾
4	2.9	4.8	1.6	10	20	Cross recessed head screw for precision equipment M2.5 × 7	643	1 220	6.3	2.7 15.4	2.3 13.0	LWLFC 10...B
	M 3 Through	—	—			(not appended) ⁽²⁾						LWLFC 10...N
4	2.9	4.8	1.6	10	20	Cross recessed head screw for precision equipment M2.5 × 7	760	1 570	8.1	4.4 23.3	3.7 19.5	LWLF 10...B
	M 3 Through	—	—			(not appended) ⁽²⁾						LWLF 10...N
5.5	3.5	6	3.2	15	30	Hexagon socket head bolt M3 × 8	1 120	1 770	12.6	4.0 25.6	3.3 21.4	LWLFC 14...B
	M 4 Through	—	—			(not appended) ⁽²⁾						LWLFC 14...N
5.5	3.5	6	3.2	15	30	Hexagon socket head bolt M3 × 8	1 580	2 940	21.0	10.4 56.7	8.7 47.6	LWLF 14...B
	M 4 Through	—	—			(not appended) ⁽²⁾						LWLF 14...N
5.5	3.5	6	3.2	15	30	Hexagon socket head bolt M3 × 8	2 040	4 320	30.9	21.8 108	18.3 90.8	LWLFG 14...B
	M 4 Through	—	—			(not appended) ⁽²⁾						LWLFG 14...N
7	3.5	6.5	4.5	15	30	Hexagon socket head bolt M3 × 8	1 360	2 200	20.1	5.8 37.2	4.8 31.3	LWLFC 18...B
	M 4 Through	—	—			(not appended) ⁽²⁾						LWLFC 18...N
7	3.5	6.5	4.5	15	30	Hexagon socket head bolt M3 × 8	2 010	3 960	36.2	17.5 93.4	14.7 78.4	LWLF 18...B
	M 4 Through	—	—			(not appended) ⁽²⁾						LWLF 18...N
7	3.5	6.5	4.5	15	30	Hexagon socket head bolt M3 × 8	2 500	5 500	50.3	33.0 165	27.7 139	LWLFG 18...B
	M 4 Through	—	—			(not appended) ⁽²⁾						LWLFG 18...N

Note⁽¹⁾: Steel balls are not retained in LWLF 4, LWLFC 6, LWLFC 6...N, LWLF 6, and LWLF 6...N. These models are not provided with end seals and an oil hole.

⁽²⁾: Prepare track rail mounting bolts with a proper bolt length ℓ such that the fixing depth becomes less than H₄.

⁽³⁾: Track rail lengths L are shown in Table 17.

⁽⁴⁾: The directions of basic dynamic load rating (C), basic static load rating (C₀), and static moment rating (T₀, T_x, and T_y) are shown in the sketches below.

The upper values in the T_x and T_y columns apply to one slide unit, and the lower values apply to two slide units in close contact.

Remarks 1. The mark ☆ indicates that interchangeable specification products are available.

2. The appended bolts for mounting track rails are hexagon socket head bolts of JIS B 1176 or equivalent, or cross recessed head screws for precision equipment. For stainless steel series Linear Way L, stainless steel bolts or screws are appended.

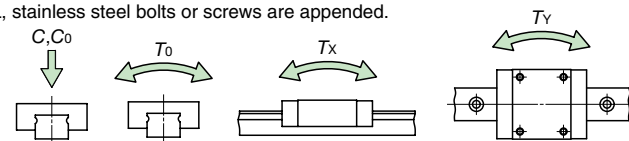

Example of identification number of assembled set

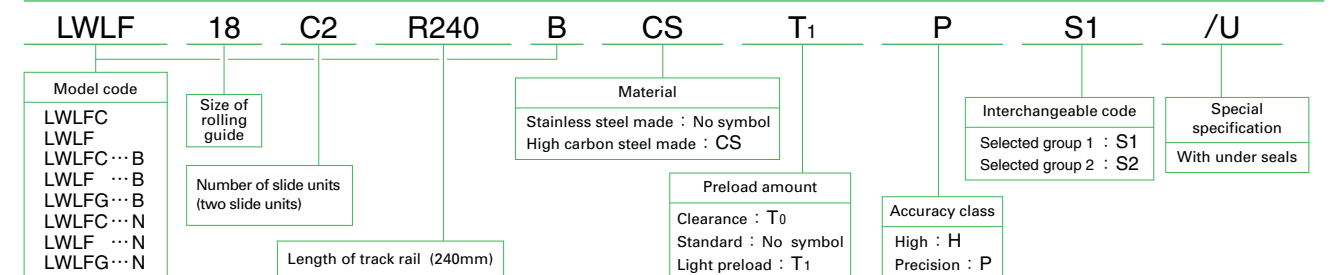

1N=0.102kgf=0.2248lbs.
1mm=0.03937inch

IKO Linear Way L: Wide rail type
LWLFC, LWLF, LWLFG

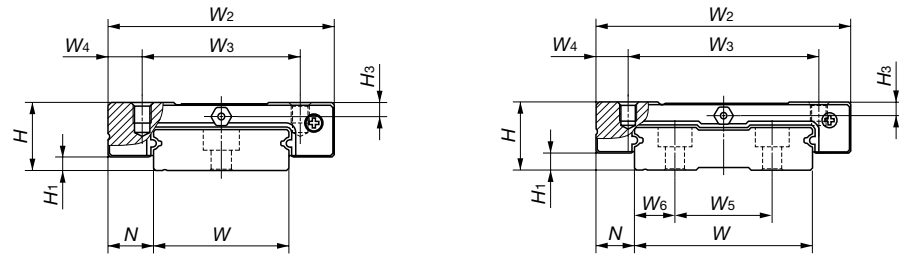

LWLFC 42...B
 LWLF 42...B (CS)
 LWLFG 42...B

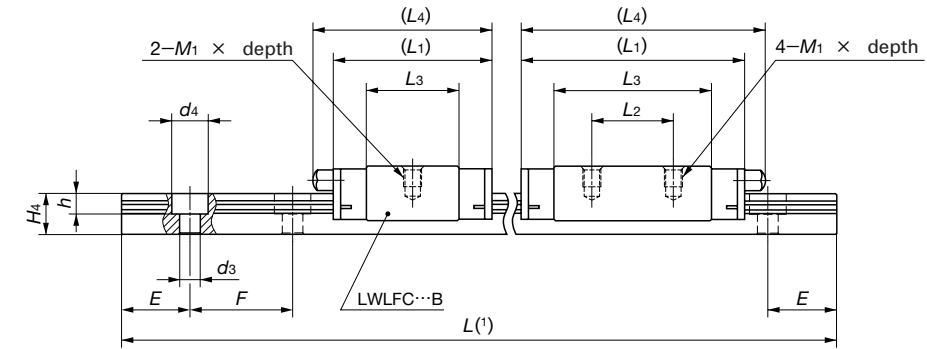

Model number	Interchangeable	Mass (Ref.) g		Dimensions of assembly mm			Dimensions of slide unit mm										
		Slide unit	Track rail (per 100 mm)	H	H ₁	N	W ₂	W ₃	W ₄	L ₁	L ₂	L ₃	L ₄	M ₁ × depth	H ₃	W	H ₄
LWLFC 24...B	☆	45	139	14	3	8	40	28	6	30.5	—	17.7	—	M3 × 3.5	3.2	24	8
LWLF 24...B	☆	76								44	15	31					
LWLF 24...BCS	☆	111								59	28	46.3					
LWLFG 24...B	☆	111								59	28	46.3					
LWLFC 30...B	☆	70	198	15	3	10	50	35	7.5	35.5	—	20.5	40	M4 × 4.5	3.1	30	9
LWLF 30...B	☆	112								50	18	34.8	54				
LWLF 30...BCS	☆	170								68.5	35	53.8	73				
LWLFG 30...B	☆	170								68.5	35	53.8	73				
LWLFC 42...B	☆	95	294	16	4	9	60	45	7.5	41.5	—	25.3	46	M4 × 4.5	3.2	42	10
LWLF 42...B	☆	140								55	20	39	60				
LWLF 42...BCS	☆	204								74.5	35	58.3	79				
LWLFG 42...B	☆	204								74.5	35	58.3	79				

Note⁽¹⁾: Track rail lengths L are shown in Table 17.
⁽²⁾: The directions of basic dynamic load rating (C), basic static load rating (C₀), and static moment rating (T₀, T_x, and T_y) are shown in the sketches below.

- Remarks
- The mark ☆ indicates that interchangeable specification products are available.
 - The appended bolts for mounting track rails are hexagon socket head bolts of JIS B 1176 or equivalent, or cross recessed head screws for precision equipment. For stainless steel series Linear Way L, stainless steel bolts or screws are appended.
 - An oil hole is provided for LWLFC 24...B, LWLF 24...B, LWLF 24...BCS, and LWLFG 24...B.

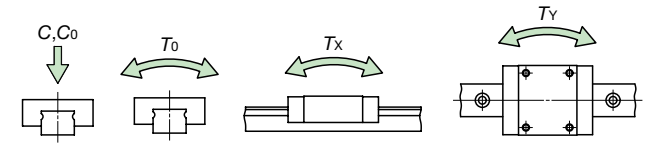

Dimensions of track rail mm							Appended mounting bolt for track rail mm Bolt size × ℓ	Basic dynamic load rating ⁽²⁾ C N	Basic static load rating ⁽²⁾ C ₀ N	Static moment rating ⁽²⁾			Model number
W ₅	W ₆	d ₃	d ₄	h	E	F				T ₀ N-m	T _x N-m	T _y N-m	
—	—	4.5	8	4.5	20	40	M4 × 10	2 500	3 460	42.2	10.1 70.2	8.5 58.9	LWLFC 24...B
—	—	4.5	8	4.5	20	40	M4 × 10	3 780	6 430	78.4	31.8 174	26.7 146	LWLF 24...B LWLF 24...BCS
—	—	4.5	8	4.5	20	40	M4 × 10	4 870	9 400	115	65.6 333	55.0 280	LWLFG 24...B
—	—	4.5	8	4.5	20	40	M4 × 12	3 460	4 710	71.6	16.0 111	13.4 93.2	LWLFC 30...B
—	—	4.5	8	4.5	20	40	M4 × 12	5 230	8 750	133	50.5 269	42.4 226	LWLF 30...B LWLF 30...BCS
—	—	4.5	8	4.5	20	40	M4 × 12	6 730	12 800	194	104 526	87.4 442	LWLFG 30...B
23	9.5	4.5	8	4.5	20	40	M4 × 12	4 450	6 280	133	25.7 170	21.6 143	LWLFC 42...B
23	9.5	4.5	8	4.5	20	40	M4 × 12	6 150	10 200	216	63.6 346	53.3 290	LWLF 42...B LWLF 42...BCS
23	9.5	4.5	8	4.5	20	40	M4 × 12	7 910	14 900	316	131 668	110 561	LWLFG 42...B

Example of identification number of assembled set

