

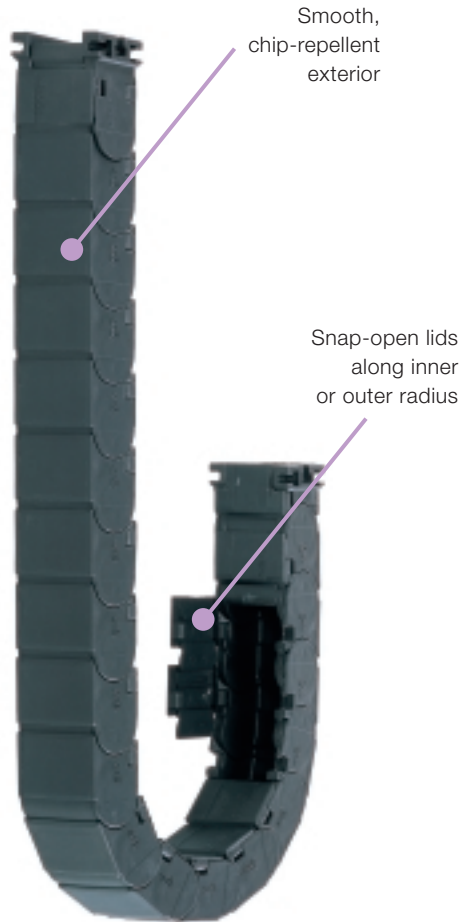

Price Index



7 Widths
7 Bending Radii



2 options for mounting brackets

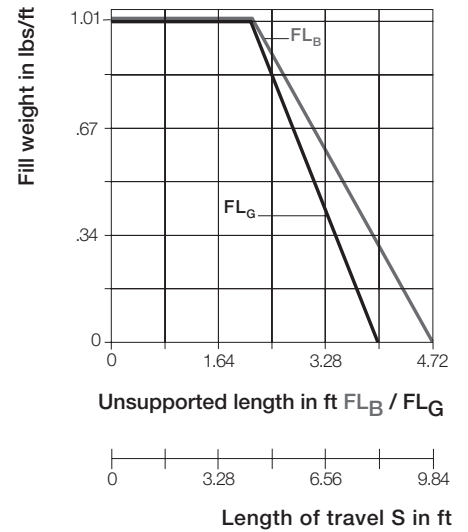

Unsupported length

- FL_B = unsupported with permitted sag
- FL_G = unsupported with straight upper run

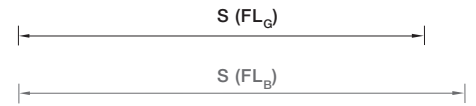
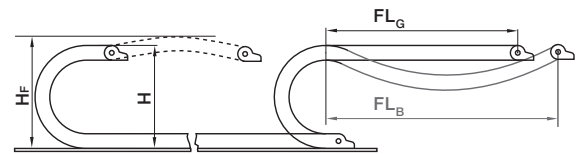

Product Range

Inner Widths (Bi) inches (mm):	.79 (020), .98 (025), 1.50 (038), 1.89 (048), 2.48 (063), 3.15 (080), 3.94 (100)
Bending Radii (R) inches (mm):	2.48 (063), 2.95 (075), 3.94 (100), 4.33 (110), 4.92 (125), 5.91 (145), 7.09 (180)
Pitch:	1.20 (30.5 mm)/link = 10.06 links/ft (33 links/m) 39.6 (1006.5 mm)



When to use the Series R117/R118:

- If snap-open accessibility along inner **or** outer radius is required
- If price is an issue
- If flush attachment is required



When not to use Series R117/R118:

- If separators are required, ► Energy Tubes E2, Series R48, **Chapter 5**
- If accessibility along sides of the radius is required ► System E4/100, Series R760, **Chapter 6**

Series R117/R118 "E2 Tubes"



R117
R118

Series R117 Energy Tube

(hinged, snap-open along both sides of the inner radius)

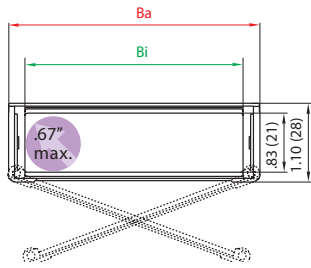

Part No.	Bi	Ba	Bending Radii for ALL Widths
117-020	.79 (020)	1.26 (32)	2.48 (063)
117-025	.98 (025)	1.46 (37)	2.95 (075)
117-038	1.50 (038)	1.97 (50)	3.94 (100)
117-048	1.89 (048)	2.40 (60)	4.33 (110)
117-063	2.48 (063)	2.95 (75)	4.92 (125)
117-080	3.15 (080)	3.62 (92)	5.71 (145)
117-100	3.94 (100)	4.41 (112)	7.09 (180)

Supplement part number with required radius
for example, 117-100-100-0

Series R118 Energy Tube

(hinged, snap-open along both sides of the outer radius)

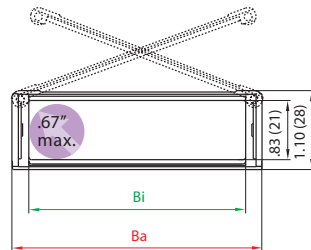

Part No.	Bi	Ba	Bending Radii for ALL Widths
118-025	.98 (025)	1.46 (37)	2.48 (063)
118-048	1.89 (048)	2.40 (60)	2.95 (075)
118-080	3.15 (080)	3.62 (92)	3.94 (100)
			4.33 (110)
			4.92 (125)
			5.71 (145)
			7.09 (180)

Supplement part number with required radius
for example, 118-100-100-0

Installation Dimensions

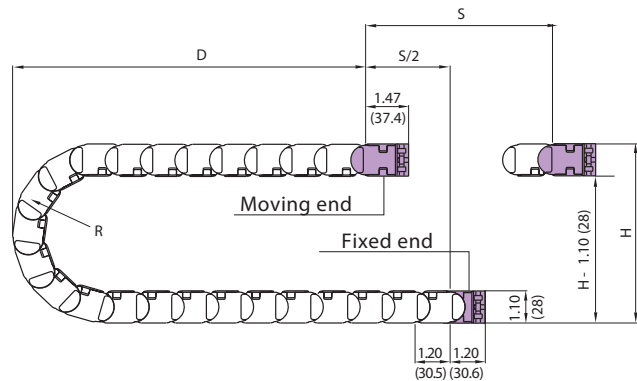

R	2.48 (063)	2.95 (075)	3.94 (100)	4.33 (110)
H*	6.06 (154)	7.01 (178)	8.98 (228)	9.76 (248)
D	4.33 (110)	4.72 (120)	5.71 (145)	6.10 (155)
K	10.24 (260)	11.81 (300)	14.76 (375)	16.14 (410)

R	4.92 (125)	5.71 (145)	7.09 (180)	
H*	10.94 (278)	12.52 (318)	15.28 (388)	
D	6.69 (170)	7.48 (190)	8.86 (225)	
K	17.91 (455)	20.47 (520)	24.80 (630)	

*The required clearance height is $HF = H + .98$ (25 mm).
Please consult igus if space is particularly restricted.

Pitch: = 1.20 (30,5 mm) per link
Links per ft (m): = 10.06 (33)
Tube length: = $\frac{S}{2} + K$



upon request

Mounting Brackets

Option 1: KMA

- Pivoting
- Short and long travels
- Space-restricted applications
- Corrosion-resistant

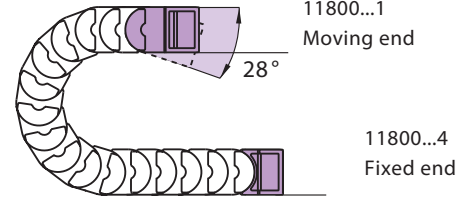

11800...4

11800...1

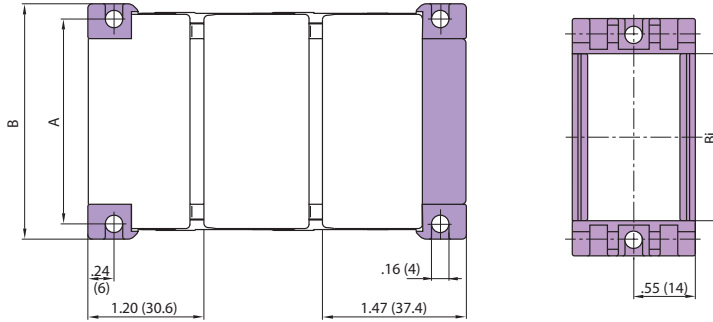

Tube Type	Part No.	Dimension A		Dimensions B	
		in.	(mm)	in.	(mm)
	Full set				
117-020	11800-020-14	1.14	(29)	1.42	(36)
117/118-025	11800-025-14	1.34	(34)	1.61	(41)
117-038	11800-038-14	1.85	(47)	2.13	(54)
117/118-048	11800-048-14	2.24	(57)	2.52	(64)
117-063	11800-063-14	2.83	(72)	3.11	(79)
117/118-080	11800-080-14	3.50	(89)	3.78	(96)
117-100	11800-100-14	4.29	(109)	4.57	(116)

11800...12 = Full set, each part with pin/bore

11800...1 = Mounting bracket with bore

11800...4 = Mounting bracket with pin

● The mounting brackets are supplied with fitted square nuts and can be attached with M4 bolts, or the mounting brackets may also be attached with M4 socket head cap bolts.

Option 2: polymer bracket

- Attachment option for strain relief tiewrap plate
- Solid connection to Energy Tube
- Minimized external width
- Long travels

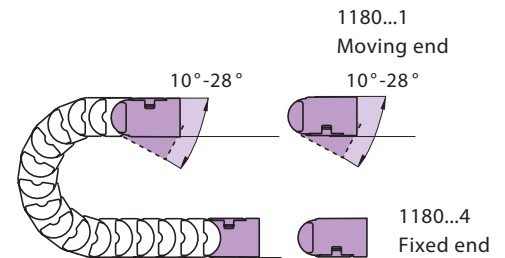

11800...4

11800...1

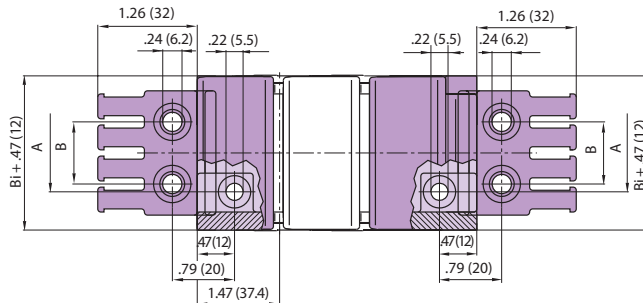

1180...14 = Full set, each part with pin/bore

1180...1 = Mounting bracket with bore

1180...4 = Mounting bracket with pin

Tube Type	Part No. Full set with Tiewrap Plate	Part No. Full Set	Dimension A		Dimensions B	
			in.	(mm)	in.	(mm)
117/118-025	1180-025-14 PZB	1180-025-14PZ	.47	(12)	.59	(15)
117-038	1180-038-14 PZB	1180-038-14PZ	1.06	(27)	.79	(20)
117/118-048	1180-048-14 PZB	1180-048-14PZ	1.46	(37)	1.18	(30)
117-063	1180-063-14 PZB	1180-063-14PZ	2.05	(52)	1.57	(40)
117/118-080	1180-080-14 PZB	1180-080-14PZ	2.72	(69)	2.36	(60)
117-100	1180-100-14 PZB	1180-100-14PZ	3.50	(89)	3.15	(80)

The following parts are required for attachment of the mounting brackets:

- Countersunk bolt M5* DIN 912-8.8
4 pieces/set
- Hexagon nut M5 DIN 934-8
4 pieces/set

* The length of the countersunk bolt is dependent on the thickness of the attachment base

Order Example and Technical Data: Series R117/R118 "E2 Tubes"

Order example

117-100...

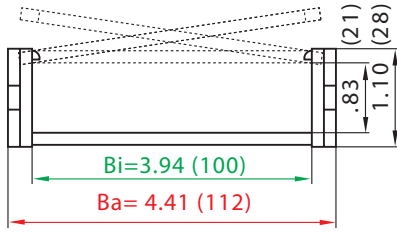

1. Tube selection:

- 117-100-100-0
- Color black
 - Radius
 - Width
 - Tube type

2. Mounting brackets:

- 11800-100-14
- Full set, pivoting (2 ea.)
 - Tube width

For 16.4 ft (5 m) tube, color black,
with pivoting mounting brackets:
16.4 ft (5 m) 117-100-100-0 and 11800-100-14

165 links – 10.06 links/ft (33 links/m)



3. Other technical data on guide troughs available upon request

Technical data

Tube Type	Weight Per Link		Weight	
	(oz.)	(g)	(lbs/ft)	(kg/m)
117-020	0.46	(≈ 13)	0.29	(≈ 0.43)
117/118-025	0.49	(≈ 14)	0.31	(≈ 0.46)
117-038	0.60	(≈ 17)	0.38	(≈ 0.56)
117/118-048	0.70	(≈ 20)	0.44	(≈ 0.66)
117-063	0.81	(≈ 23)	0.51	(≈ 0.76)
117/118-080	0.97	(≈ 27)	0.60	(≈ 0.89)
117-100	1.12	(≈ 32)	0.71	(≈ 1.06)

Material	igumid G
Permitted temperature	-40°/+266°F (-40°/+130°C)
Gliding speed max.	4.92ft/s (1.5 m/s)
Unsupported V max.	32.8 ft/s (10 m/s)
Flammability class	VDE 0304 IIC UL94 1H

● Details of material properties

▶ Design, Chapter 1



upon request