

### Price Index



15 Widths  
6 Bending Radii



Low-noise design



Interior separation possible



KMA mounting brackets



Results of cleanroom tests available

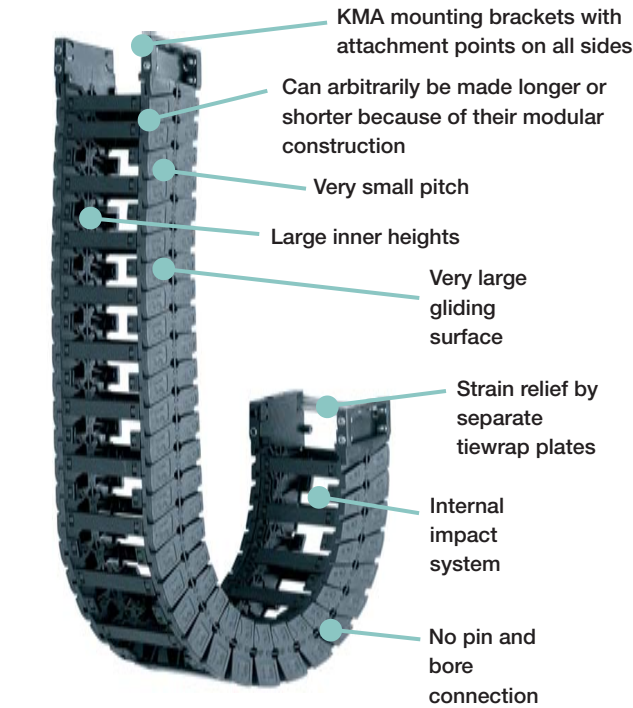

### Product Range:

Inner Widths (Bi) inches (mm):	1.57 (40) - 11.81 (300)
Bending Radii (R) inches (mm):	2.48 (063), 2.95 (075), 3.94 (100), 4.92 (125) 5.91 (150), 7.87 (200)
Pitch:	1.09 (27.8 mm/link) = 11 links/ft (36 links/m) 39.4 (1012 mm)



### When to use the Series E6-40:

- If extremely quiet operation is required
- If very high speeds and/or accelerations are required
- If large stresses and thrust forces are part of the application
- For small bending radii
- When low vibration is important
- For very low wear, suitable for cleanrooms



### When not to use the Series E6-40:

- For side-mounted applications  
▶ Series 280 System E4, Chapter 6
- For RBR (reversed bend radius)  
▶ Series 280/380 System E4, Chapter 6
- For extremely high additional loads  
▶ Series 280/380 System E4, Chapter 6
- For very dirty environments  
▶ Series 280/380 System E4, Chapter 6

- Accessories for  
▶ Guide Troughs, Chapter 9
- Further information  
▶ Design, Chapter 1

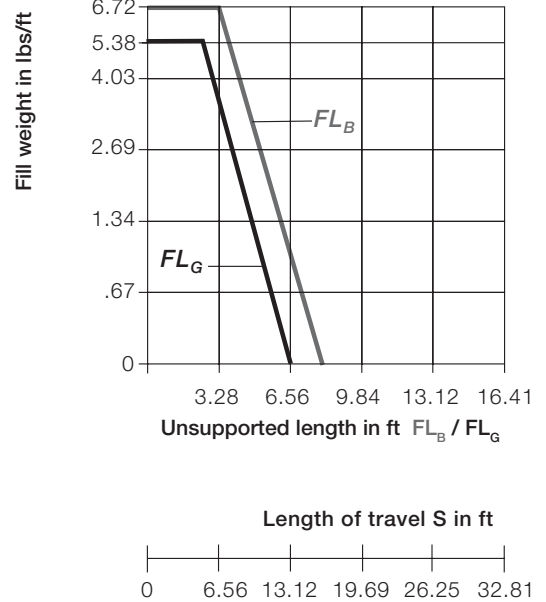

### Unsupported length

- $FL_B$  = unsupported with permitted sag
- $FL_G$  = unsupported with straight upper run

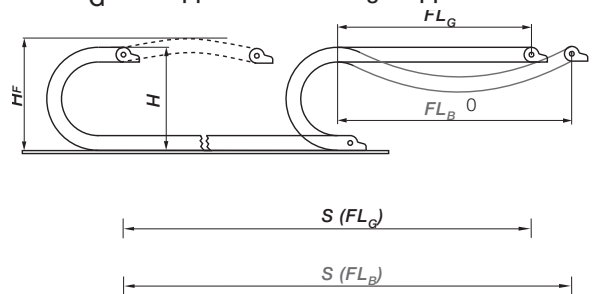

Unsupported Energy Chains® ▶ **Design, Chapter 1**, feature positive camber over short travels. This must be accounted for when specifying the clearance height. Please refer to **Installation dimensions** for further details.

If the unsupported length is exceeded, the Energy Chain®/Tube must glide on itself. This requires a guide trough ▶ **Design, Chapter 1** or incorporation of igus® exclusive AUTO-GLIDE System guide elements, which are available for this chain series ▶ **AUTO-GLIDE System, Chapter 9**.

### Other Installation Methods:

<b>Vertical, hanging</b>	= max 98.4 ft (30 m)
<b>Vertical, standing</b>	= max 6.56 ft (2 m)
<b>Rotary</b>	= requires further calculation

- Long travel Max: 197 ft (60 m)

Series E6-40 Energy Chain

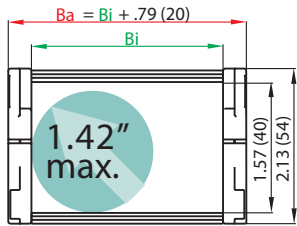

Supplement part no. with required radius for example, E6-40-100-075-0

Part No.	Bi	Ba
E6-40-040	1.57 (40)	2.20 (60)
E6-40-050	1.97 (50)	2.76 (70)
E6-40-062	2.44(62)	3.23 (82)
E6-40-070	2.76 (70)	3.54 (90)
E6-40-075	2.95 (75)	3.74 (95)
E6-40-087	3.43 (87)	4.21 (107)
E6-40-100	3.93 (100)	4.72 (120)
E6-40-125	4.92 (125)	5.71 (145)
E6-40-150	5.91 (150)	6.69 (170)
E6-40-175	6.89 (175)	7.68 (195)
E6-40-200	7.87 (200)	8.66 (220)
E6-40-225	8.86 (225)	9.65 (245)
E6-40-250	9.84 (250)	10.63 (270)
E6-40-275	10.83 (275)	11.61 (295)
E6-40-300	11.81 (300)	12.60 (320)

Bending Radii for ALL Widths  
 2.48 (063)  
 2.95 (075)  
 3.94 (100)  
 4.92 (125)  
 5.91 (150)  
 7.87 (200)

Installation Dimensions

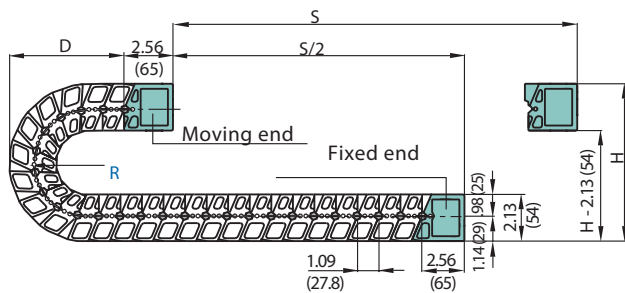

- Pitch: = 1.09 (27.8 mm) per link
- Links per ft (m): = 10.97 (36)
- Total Travel: = S
- Chain length: =  $\frac{S}{2} + K$

R	2.48 (063)	2.95 (075)	3.94 (100)
H*	7.24 (184)	8.19 (208)	10.16 (258)
D	4.72 (120)	5.20 (132)	6.18 (157)
K	10.04 (255)	11.61 (295)	14.57 (370)

R	4.92 (125)	5.91 (150)	7.87 (200)
H*	12.12 (308)	14.09 (358)	18.03 (458)
D	7.56 (192)	8.15 (207)	10.12 (257)
K	18.11 (460)	20.87 (530)	26.97 (685)

\*The required clearance height is  $H_F = H + 1.57 (40 \text{ mm})$  with 1.68 (2.5 kg/m) fill weight. Please consult igus if space is particularly restricted.

Interior Separation

Vertical Separators and Shelves

Energy Chains and Energy Tubes can be subdivided both vertically and horizontally using the various interior separation elements.

For layout recommendations, see Design, Chapter 1

Width X in. (mm)	Part No. Unassembled	Part No. Assembled
2.95 (075)	220-75	221-75
3.94 (100)	220-100	221-100
4.92 (125)	220-125	221-125
5.91 (150)	220-150	221-150
6.89 (175)	220-175	221-175
7.87 (200)	220-200	221-200

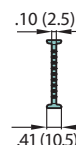
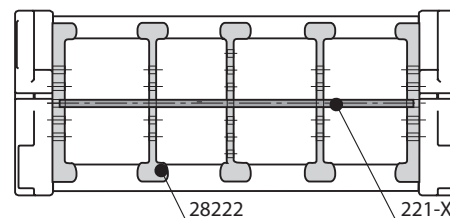
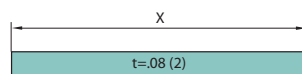

Vertical Separator, slotted

Unassembled	Part No. 28221
Assembled	Part No. 28222

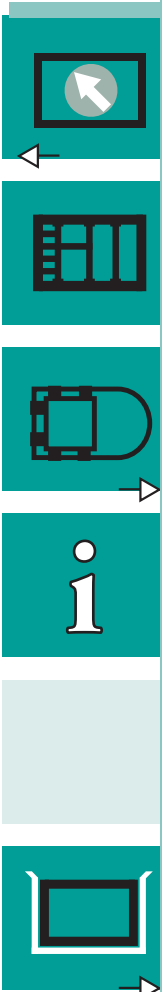

## Mounting Brackets

Option: KMA pivoting

- Bolts to machine
- Pivots in one direction
- Easy to assemble

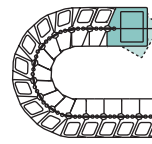
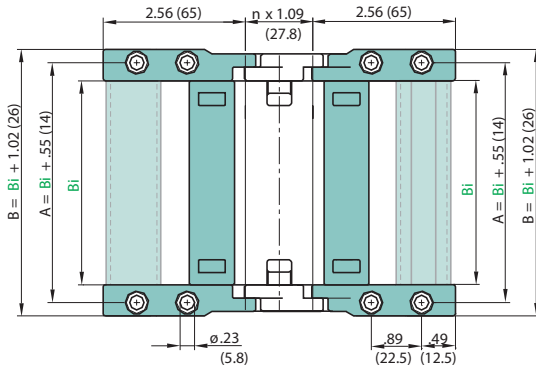
E6-400-20/21  
Moving endE6-400-10/11  
Fixed end

Chain Type	Part No. Full Set without profile rail	Part No. Full Set with profile rail	Dimension A		Dimension B	
			in.	(mm)	in.	(mm)
E6-40-040	E6-400-040-12	E6-400-040-12P	2.13	(54)	2.60	(66)
E6-40-050	E6-400-050-12	E6-400-050-12P	2.52	(64)	2.99	(76)
E6-40-062	E6-400-062-12	E6-400-062-12P	2.99	(76)	3.46	(88)
E6-40-070	E6-400-070-12	E6-400-070-12P	3.31	(84)	3.78	(96)
E6-40-075	E6-400-075-12	E6-400-075-12P	3.50	(89)	3.98	(101)
E6-40-087	E6-400-087-12	E6-400-087-12P	3.98	(101)	4.45	(113)
E6-40-100	E6-400-100-12	E6-400-100-12P	4.49	(114)	4.96	(126)
E6-40-125	E6-400-125-12	E6-400-125-12P	5.47	(139)	5.94	(151)
E6-40-150	E6-400-150-12	E6-400-150-12P	6.46	(164)	6.93	(176)
E6-40-175	E6-400-175-12	E6-400-175-12P	7.44	(189)	7.91	(201)
E6-40-200	E6-400-200-12	E6-400-200-12P	8.43	(214)	8.90	(226)
E6-40-225	E6-400-225-12	E6-400-225-12P	9.41	(239)	9.88	(251)
E6-40-250	E6-400-250-12	E6-400-250-12P	10.39	(264)	10.87	(276)
E6-40-275	E6-400-275-12	E6-400-275-12P	11.38	(289)	11.85	(301)
E6-40-300	E6-400-300-12	E6-400-300-12P	12.36	(314)	12.83	(326)

Order example

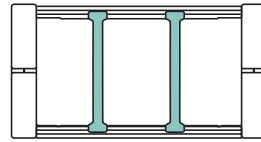
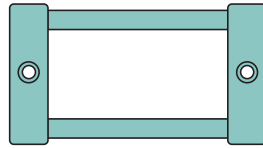
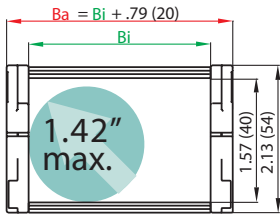

1. Chain selection:

E6-40-100-075-0

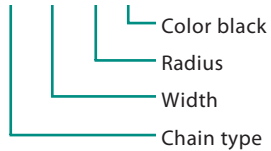

2. Mounting brackets:

E6-400-100-12P

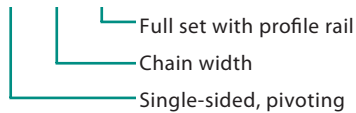

3. Interior separation:

2 separators assembled every other link (Part No. 28222).  
Alternative interior separation configuration according to design layout possible.

For 6.56 ft (2 m) chain, color black, with pivoting mounting brackets  
6.56 ft (2 m) E6-40-100-175-0 and E6-400-100-12



Technical data

Chain Type	Weight	
	(lbs/ft)	(kg/m)
E6-40-040	0.87	(1.29)
E6-40-050	0.89	(1.33)
E6-40-062	0.93	(1.38)
E6-40-070	0.95	(1.41)
E6-40-075	0.96	(1.43)
E6-40-087	0.99	(1.48)
E6-40-100	1.03	(1.53)
E6-40-125	1.10	(1.63)

Material	igumid G
Permitted temperature	-40°/+266°F (-40°/+130°C)
Gliding speed max.	16.4 ft/s (5 m/s)
Unsupported V max.	32.8 ft/s (10 m/s)
Flammability class	VDE 0304 IIC UL94 1H

● Details of material properties

▶ Design, Chapter 1



### Guide Troughs

Guide troughs are used with applications where the upper run of the Energy Chain® glides on the lower run. If using igus® steel guide troughs, the following components are required:

- Full travel length of guide trough  
Part Number 98-30
- 1/2 travel length of glide bars  
Part Number 92-01
- Installation sets as end connectors  
Part Number 93-50-XX

-XX indicates the length of the profile rail on which the guide trough is mounted. The values and part numbers are specified in the table on the left. The standard length of the trough components and glide bars is 6.56 ft (2 m.) The required overall length of the guide trough directly correlates to the length of travel.

Example :  
Length of travel 164 ft (50 m)  
Center mounted

- Required guide troughs:  
164 ft (50 m) guide trough  
82 ft (25 m) glide bar  
= 25 sections of 6.56 ft (2 m) guide trough  
Part No. 98-30
- = 13 sections of 6.56 ft (2 m) glide bar  
Part No. 92-01



Required number of installation sets:  
= Number of guide trough components + 1  
= 25 + 1 = 26  
Part number of the installation sets

Example: 93-50-400 for 15.75" (400 mm) long profile rail.

Crossbar Width E6-40-100-100-0	Dimension D	Installation Part No.
-040	2.56 (65)	*
-050	2.95 (75)	93-50-200
-062	3.43 (87)	93-50-200
-070	3.74 (95)	93-50-225
-075	3.94 (100)	93-50-225
-100	4.92 (125)	93-50-250
-125	5.91 (150)	93-50-275
-150	6.89 (175)	93-50-300
-175	7.87 (200)	93-50-325
-200	8.86 (225)	93-50-350
-225	9.84 (250)	93-50-375
-250	10.83 (275)	93-50-400
-275	11.81 (300)	93-50-425
-300	12.80 (325)	93-50-450

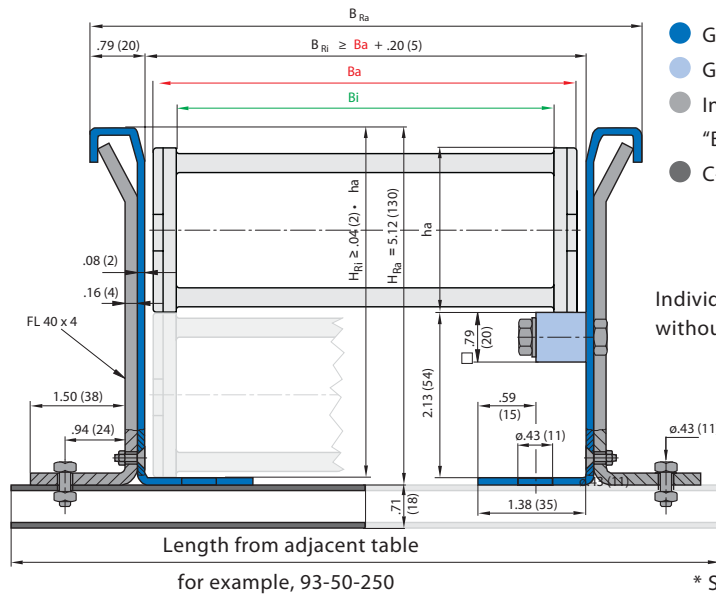

- Guide trough
- Glide bars
- Installation set "Basic"
- C-profile rail

Individual attachment without profile rail

\* Specialized guide trough available upon request

Standard length profile rail