

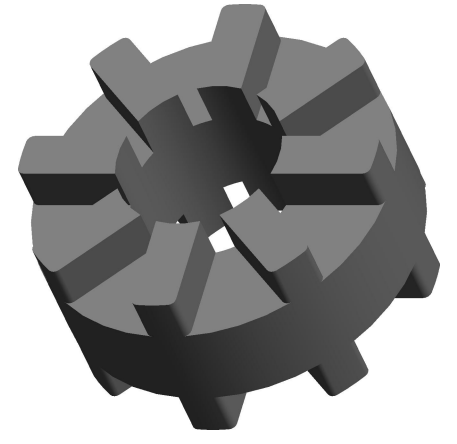

REVISIONS				
DRAWN	REV	DESCRIPTION	DATE	APPROVED
DH	00	ORIGINAL	8-26-98	DC
KP/TC	01	UPDATED FORMAT, NOTES, TOLERANCES, ADDED WEIGHT, CAVITY LOCATION, AND -X TO NAMING CONVENTION.	9-8-11	MS
TC	02	DELETED INCORRECT MATERIAL V2599 FROM TABLE	11-2-11	MS

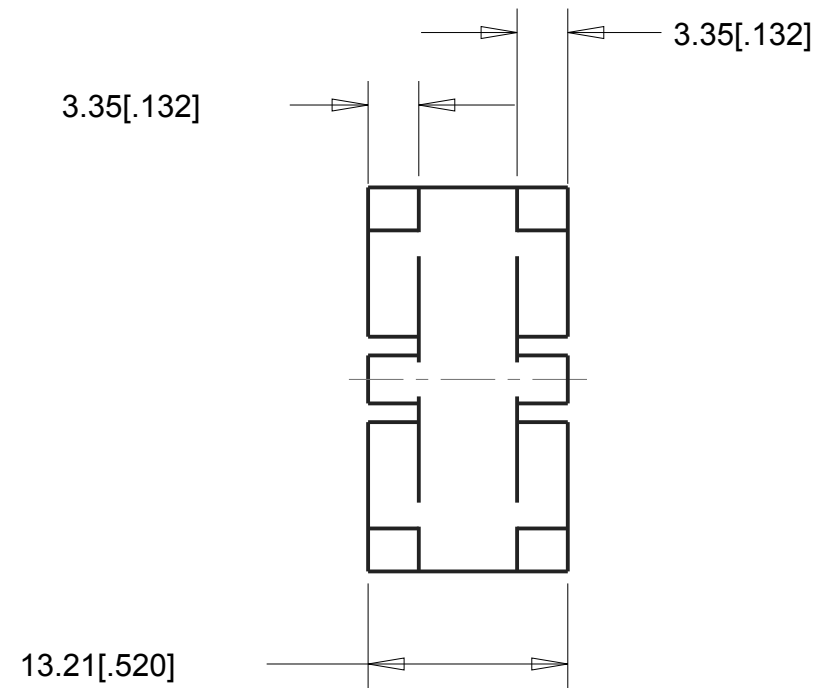
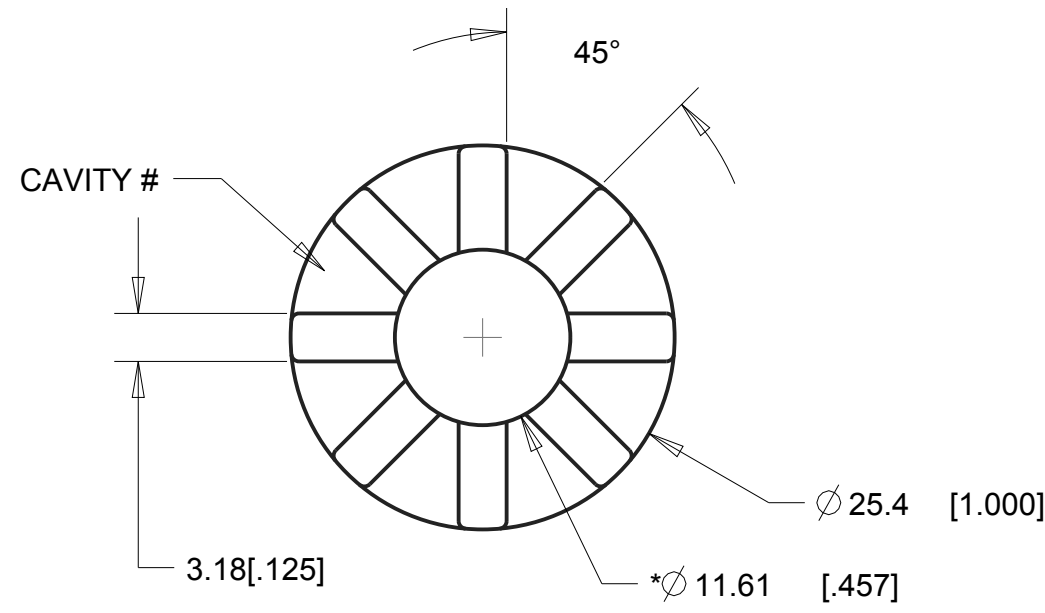

R-445-1	C-1002
R-445-2	C-1105
R-445-3	C-1100
R-445-C8012	C-8012
R-445-8	C-8002
R-445-C8001	C-8001
R-445-V2325	V-2325
R-445-V2350	V-2350
R-445-V2375	V-2375
R-445-V2525	V-2525
R-445-V2550	V-2550
R-445-V2575	V-2575
R-445-V2590	V-2590
R-445-V2725	V-2725
R-445-V2750	V-2750
R-445-V2775	V-2775
PART NUMBER	MATERIAL

- 3. MAX DRAFT: 2°.
- 2. CRITICAL DIMENSIONS SHALL HAVE Cpk VALUE >= 1.33 WITH ONGOING SPC DATA REQUIRED.
- 1. CRITICAL DIMENSIONS ARE MARKED WITH "**".

NOTES:

RANGE	TOL
0 < DIM <= 2 [0.078]	± 0.15 [0.006]
2 [0.078] < DIM <= 25 [0.98]	± 0.25 [0.010]
25 [0.98] < DIM <= 50 [1.969]	± 0.4 [0.016]
50 [1.969] < DIM	± 0.6 [0.024]

UNLESS OTHERWISE SPECIFIED UNITS ARE: MM [IN] TOLERANCE FOR ANGLES: ±1.0°		MATERIAL: SEE TABLE ON LEFT		AEARO TECHNOLOGIES LLC * a 3M company	
ALLOWABLE FLASH: .12MM [0.005]		QUALITY CONTROL: MUST COMPLY WITH E-A-R SPECIALTY COMPOSITES SUPPLIER QUALITY MANUAL REQUIREMENTS		TITLE GROMMET	
GATE: ±.25MM [0.010]		NOTES: ANY FEATURE NOT DIMENSIONED IN PRINT MUST BE VISIBLY PRESENT, UTILIZE 3D CAD FOR CREATION		SIZE B	DRAWING NO. R-445-X
4.88 GRAM REF				PAGE NO. 1 OF 1	

1

2

3

4

D

D

C

C

B

B

A

A